

| REV. | LCO No. | DESCRIPTION | DATE | APPROVED |
|------|---------|------------------------------------|----------|----------|
| A | 1015 | INITIAL RELEASE | 12/11/07 | MEC |
| B | 1314 | UPDATED FORMAT AND UPDATED DRAWING | 7/13/16 | MEC |

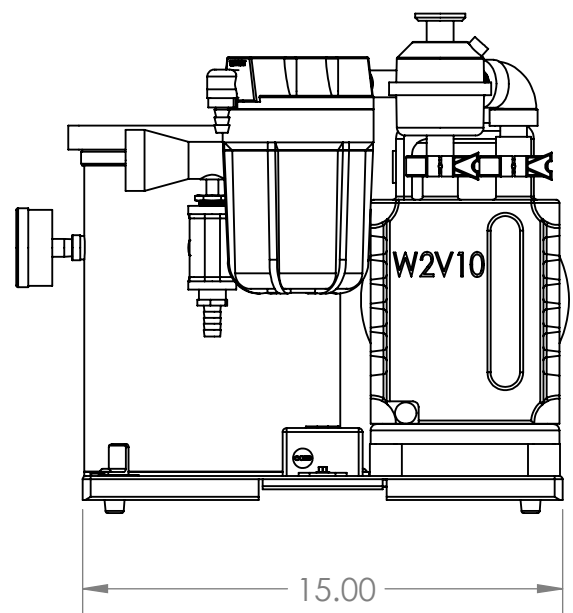

NOTES:
 1. MATL: 304 STAINLESS STEEL.
 2. ESTIMATED SYSTEM WEIGHT: 40 lbs

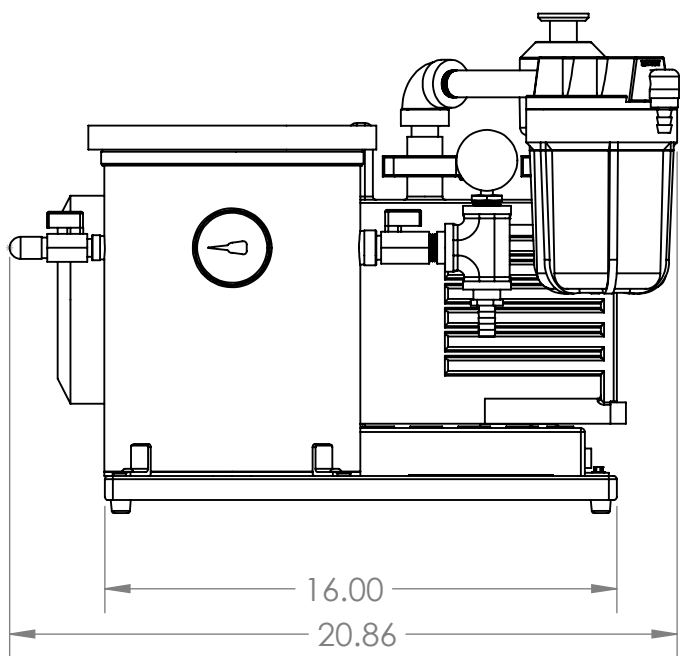
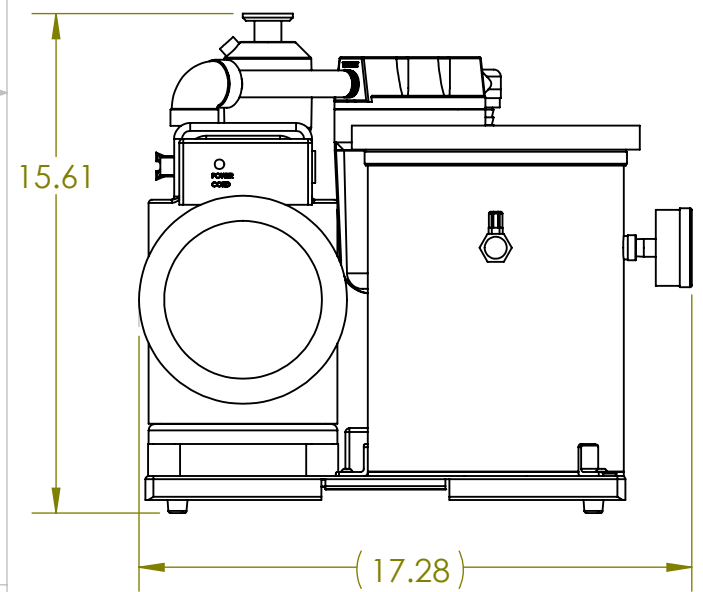
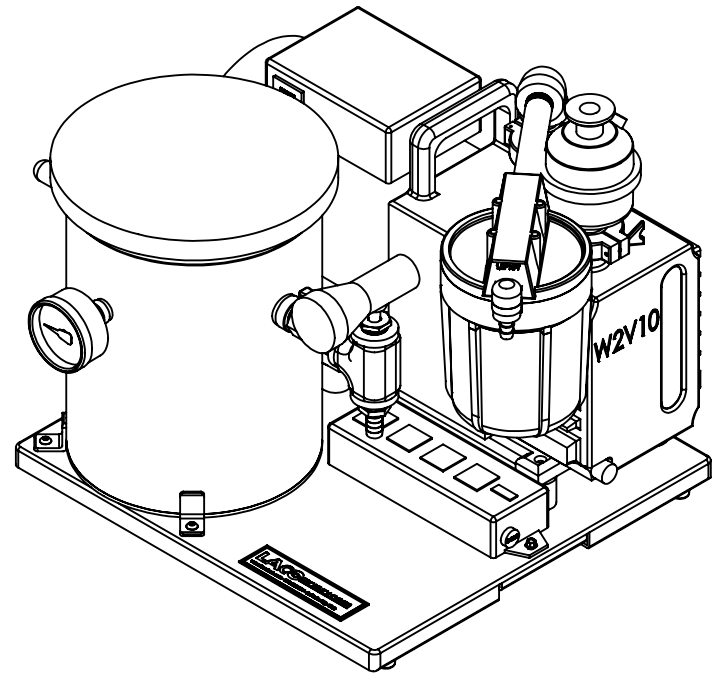
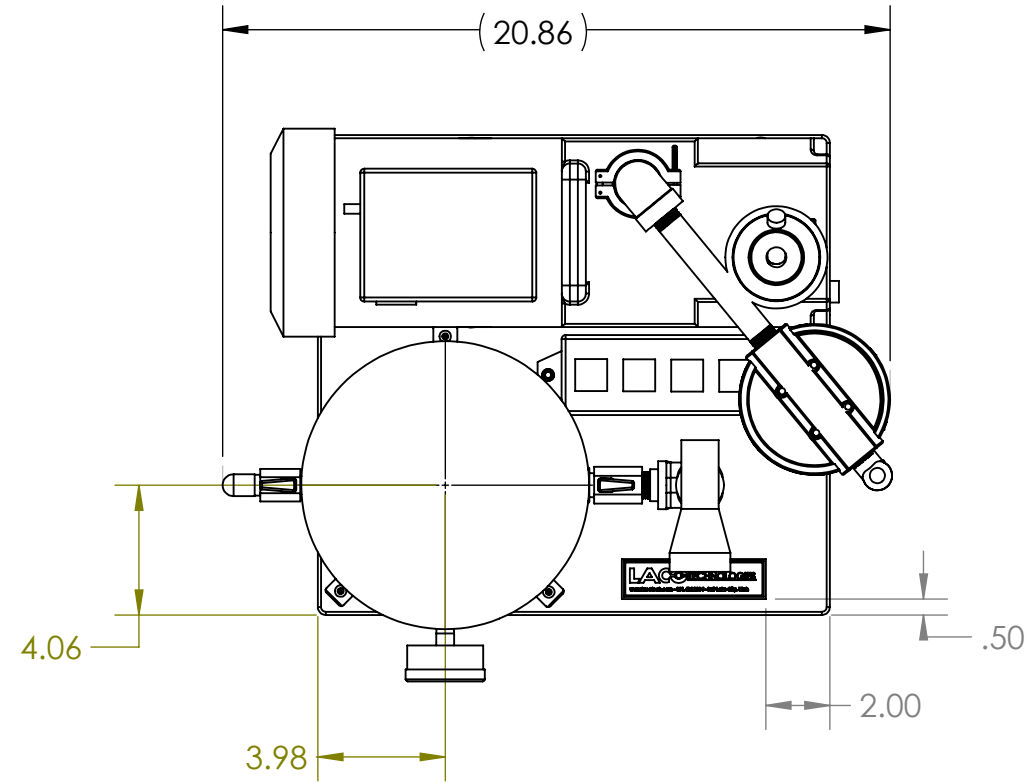

| | | | | | |
|---|---------|-------------|-------------------------------|------------------|--|
| UNLESS OTHERWISE SPECIFIED: DIMENSIONS ARE IN INCHES. TOLERANCES: FRACTIONAL: ±1/16" ANGULAR: MACH ±1° / BEND ±2° TWO PLACE DECIMAL: ±.01 THREE PLACE DECIMAL: ±.005 GEOMETRIC TOLERANCING PER ASME Y14.5M - 2009 | | | CUSTOMER DRAWING VDS08103H | | |
| DRAWN BY DVM | | NAME DVM | | DATE 7/13/16 | |
| APPROVED BY MEC | | NAME MEC | | DATE 12/11/07 | |
| DWG. NO. 92102M | | | REV B | | |
| SCALE: 1:8 | SIZE: B | | SHEET 1 OF 1 | | |