

REV.	LCO No.	DESCRIPTION	DATE	APPROVED
A	1252	INITIAL RELEASE	6/11/18	MLC

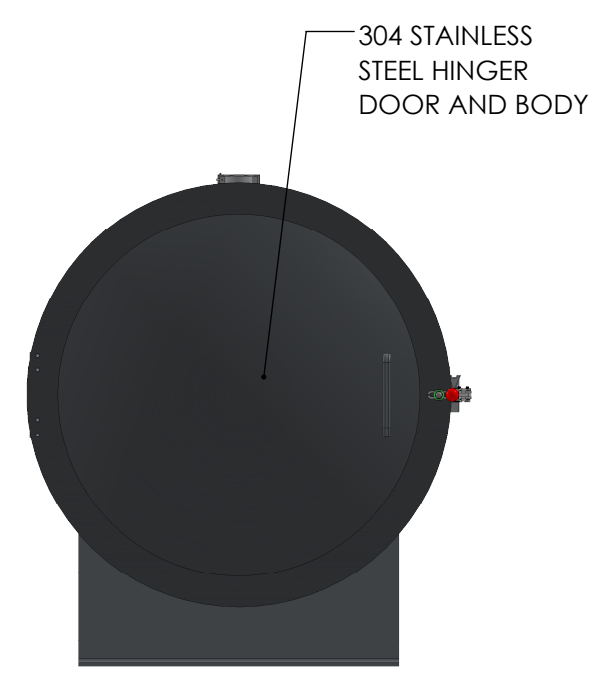
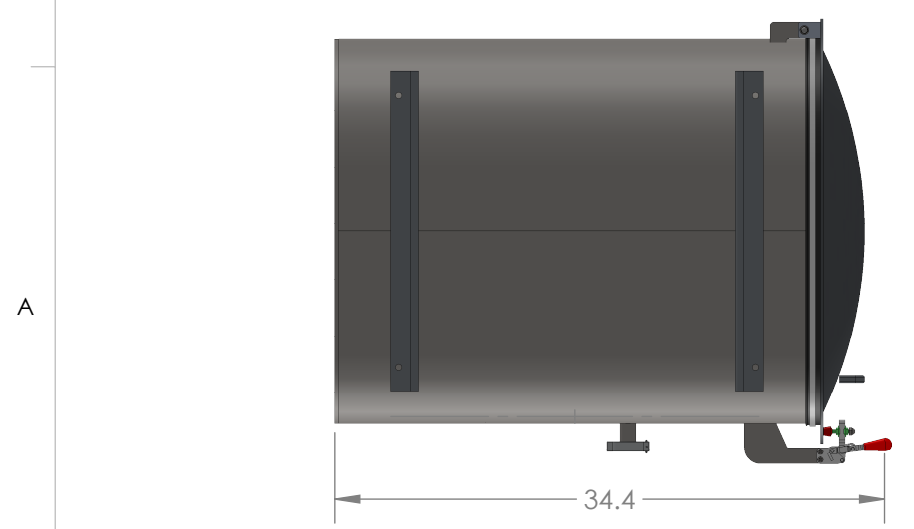
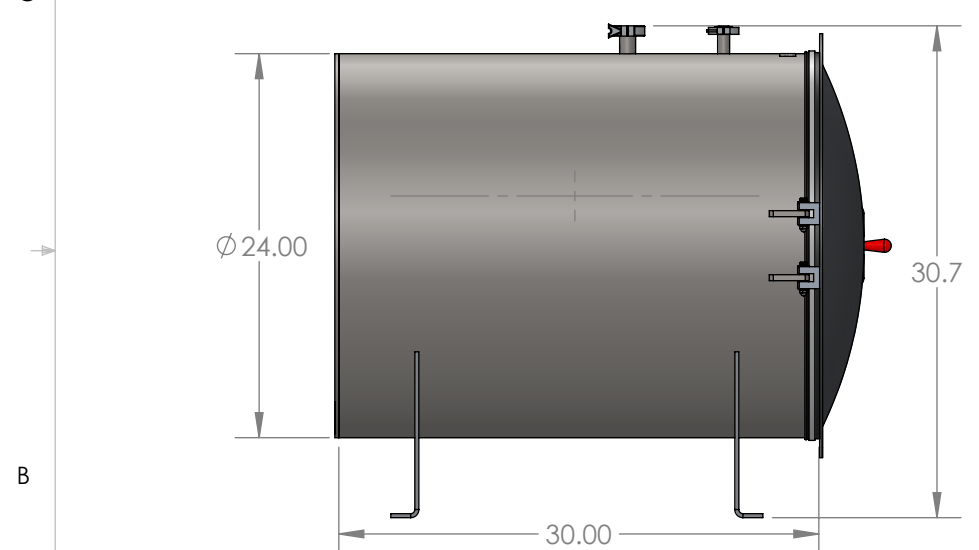
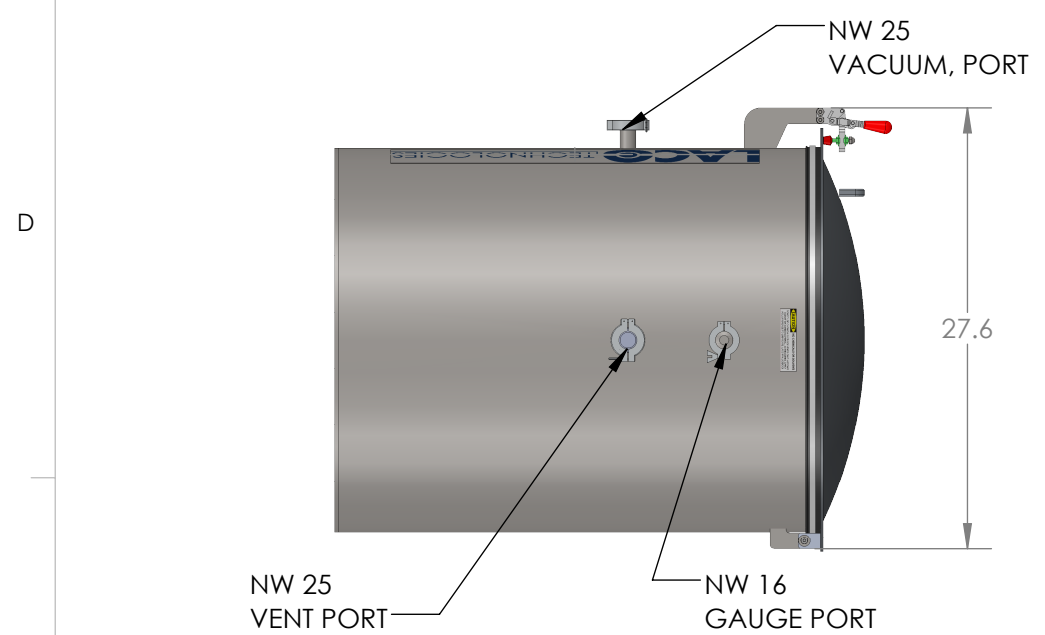

NOTES:  
 1. ESTIMATED SYSTEM WEIGHT: 210.4 lbs

**LACO TECHNOLOGIES**

UNLESS OTHERWISE SPECIFIED:  
 DIMENSIONS ARE IN INCHES.  
 TOLERANCES:  
 FRACTIONAL: ±1/16"  
 ANGULAR: MACH ±1° / BEND ±2°  
 TWO PLACE DECIMAL: ±.01  
 THREE PLACE DECIMAL: ±.005  
 GEOMETRIC TOLERANCING PER ASME Y14.5M - 2009

PROPRIETARY AND CONFIDENTIAL  
 THE INFORMATION CONTAINED IN THIS DRAWING IS THE SOLE PROPERTY OF LACO TECHNOLOGIES, INC. ANY REPRODUCTION IN PART OR AS A WHOLE WITHOUT THE WRITTEN PERMISSION OF LACO TECHNOLOGIES, INC., IS PROHIBITED.

24" OD X 30", HORIZONTAL CHAMBER

DRAWN BY	NAME	DATE
	MLC	6/11/18
APPROVED BY		
DWG. NO.	REV	
113811-C	A	
SCALE: 1:12	SIZE: B	SHEET 1 OF 1