

REV.	LCO No.	DESCRIPTION	DATE	APPROVED
A	1253	INITIAL RELEASE	10/23/2018	ABS
B		ADD MISSING DIMS	13-Mar-20	thg

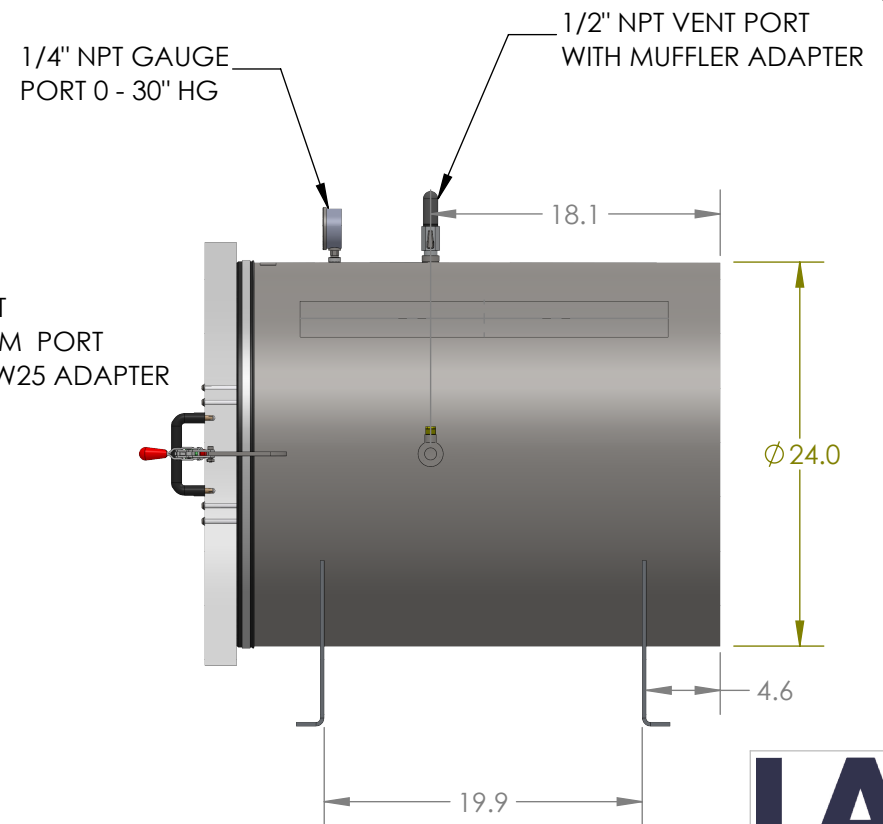

NOTES:  
1. ESTIMATED SYSTEM WEIGHT: 197 lbs

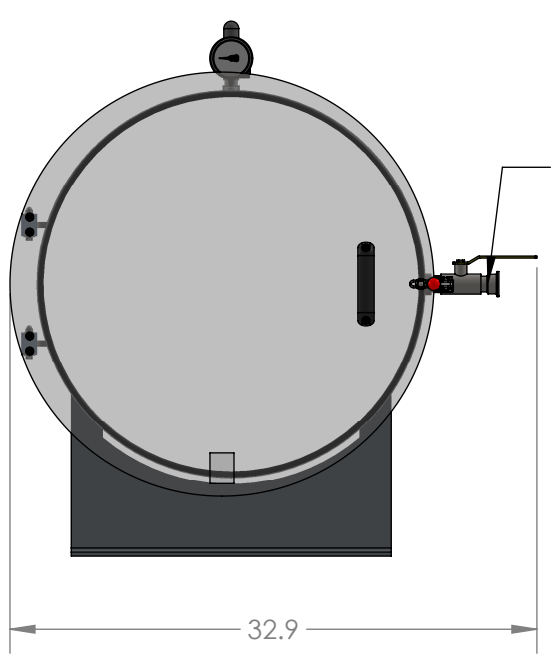
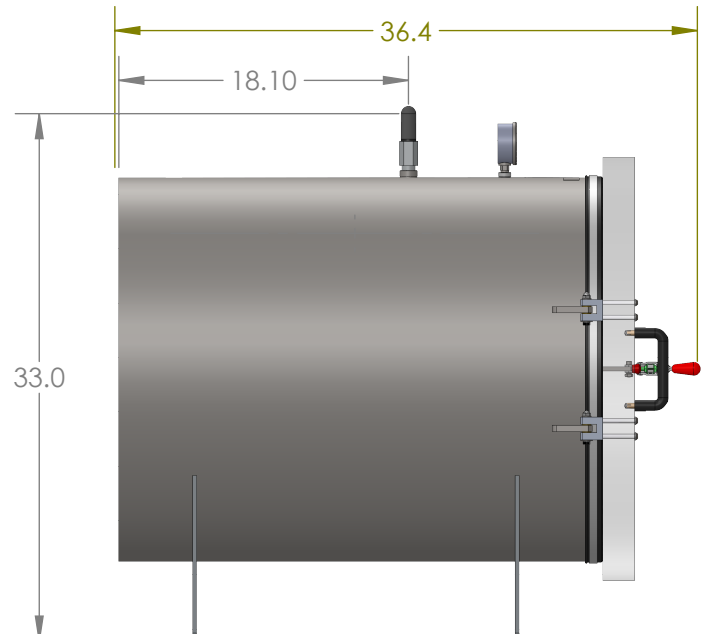
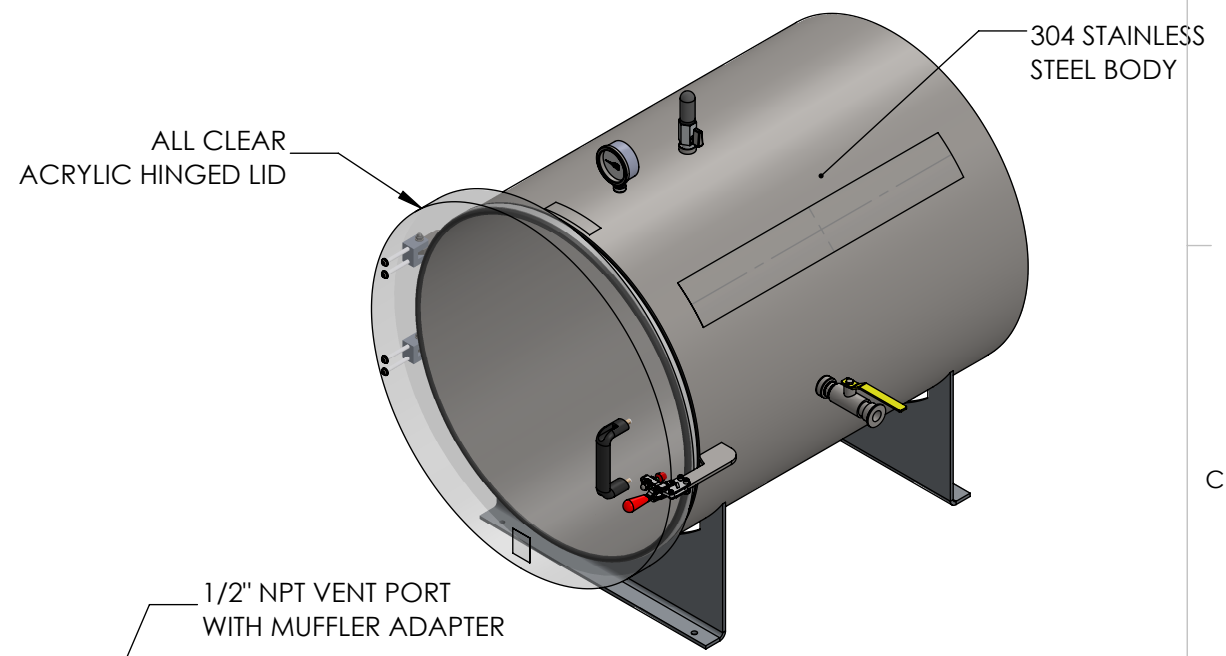
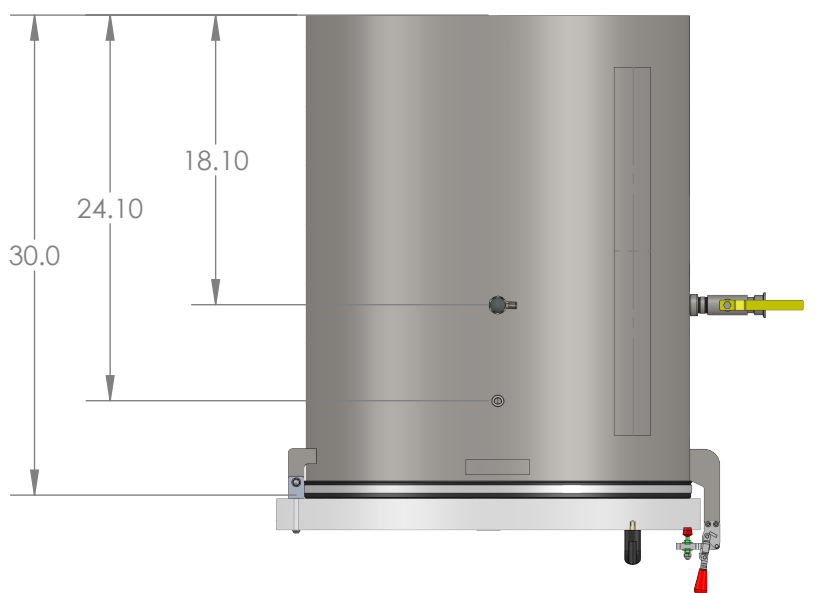

UNLESS OTHERWISE SPECIFIED: DIMENSIONS ARE IN INCHES. TOLERANCES: FRACTIONAL: ±1/16" ANGULAR: MACH ±1° / BEND ±2° ONE PLACE DECIMAL: ±.05 TWO PLACE DECIMAL: ±.01 THREE PLACE DECIMAL: ±.005 GEO TOLERANCING: ASME Y14.5M - 2009		
ASSEMBLY, CHAMBER, HORIZONTAL 24" X 30", 304SS, ACRYLIC LID STANDARD PORTS		
DRAWN BY	NAME	DATE
SEE ABAS FOR APPROVER	ABS	10/23/2018
DWG. NO.	REV	
113739-C	B	
SCALE: 1:2	SIZE: B	SHEET 1 OF 1

PROPRIETARY AND CONFIDENTIAL  
THE INFORMATION CONTAINED IN THIS  
DRAWING IS THE SOLE PROPERTY OF LACO  
TECHNOLOGIES, INC. ANY  
REPRODUCTION IN PART OR AS A WHOLE  
WITHOUT THE WRITTEN PERMISSION OF  
LACO TECHNOLOGIES, INC., IS PROHIBITED.