

REV.	LCO No.	DESCRIPTION	DATE	APPROVED
A	1253	INITIAL RELEASE	9/4/2018	ABS

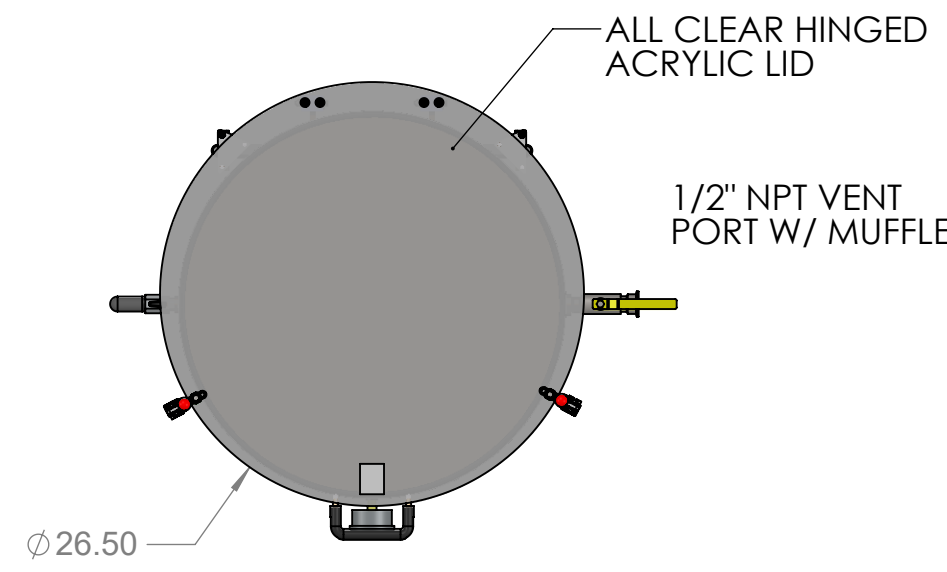

1/2" NPT VENT PORT W/ MUFFLER

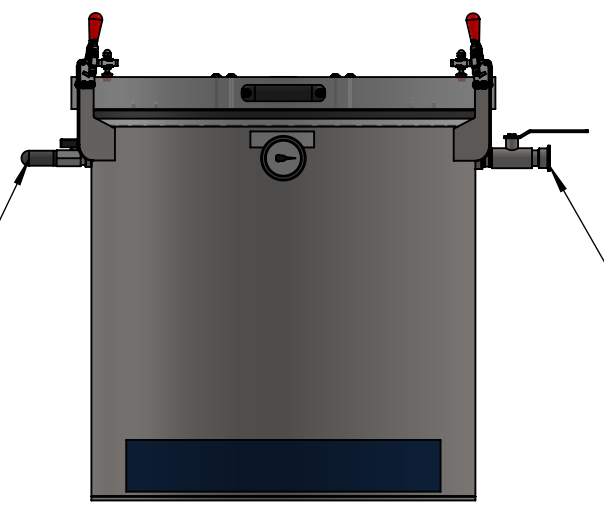

3/4" NPT VACUUM PORT, W/ NW25 ADAPTER

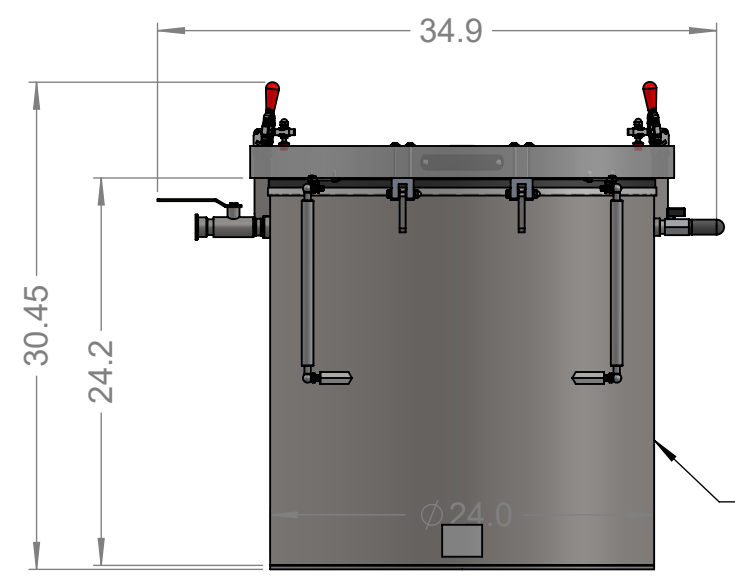
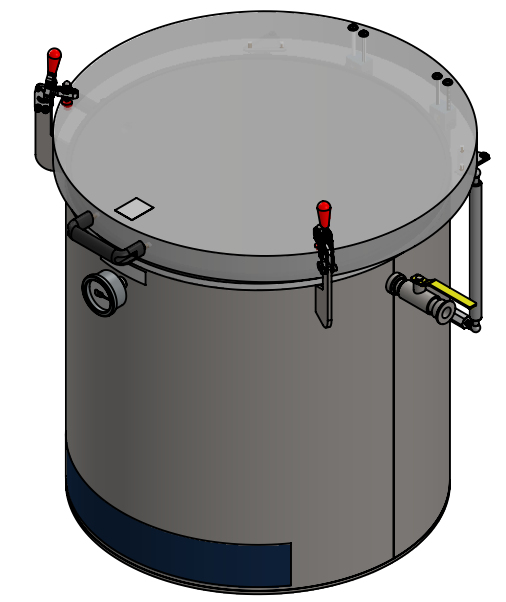

304 STAINLESS STEEL BODY

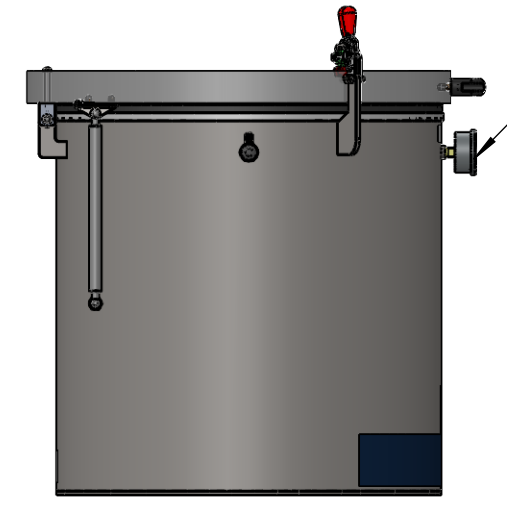

1/4" NPT VACUUM GAUGE 0-30" HG

NOTES:
1. ESTIMATED SYSTEM WEIGHT: 217 lbs



UNLESS OTHERWISE SPECIFIED:
DIMENSIONS ARE IN INCHES.
TOLERANCES:
FRACTIONAL: ±1/16"
ANGULAR: MACH ±1° / BEND ±2°
ONE PLACE DECIMAL: ±.05
TWO PLACE DECIMAL: ±.01
THREE PLACE DECIMAL: ±.005
GEO TOLERANCING: ASME Y14.5M - 2009

PROPRIETARY AND CONFIDENTIAL
THE INFORMATION CONTAINED IN THIS DRAWING IS THE SOLE PROPERTY OF LACO TECHNOLOGIES, INC. ANY REPRODUCTION IN PART OR AS A WHOLE WITHOUT THE WRITTEN PERMISSION OF LACO TECHNOLOGIES, INC., IS PROHIBITED.

24" OD X 24" VERTICAL, STAINLESS STEEL BODY, HINGED ACRYLIC LID

DRAWN BY	NAME	DATE
SEE ABAS FOR APPROVER	MLC	6/4/18
DWG. NO.	REV	
113669	A	
SCALE: 1:1	SIZE: B	SHEET 1 OF 1