

REV.	LCO No.	REV DESCRIPTION	DATE	APPROVED
A	1254	INITIAL RELEASE	7/12/2018	ABS

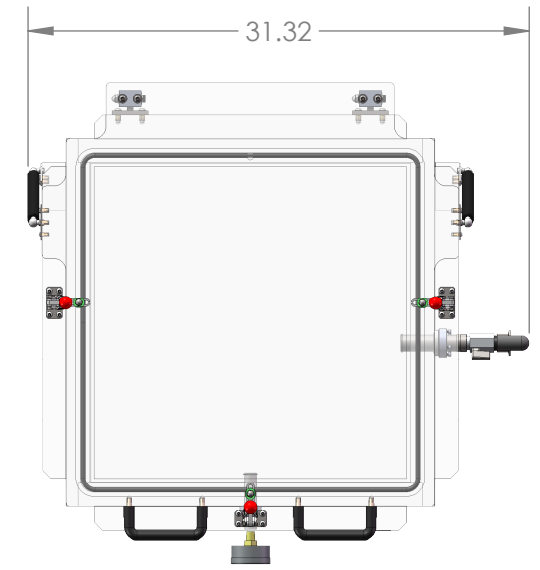

HINGED ACRYLIC LID

1/4" NPT PORT W/ 0-30" HG VACUUM GAUGE

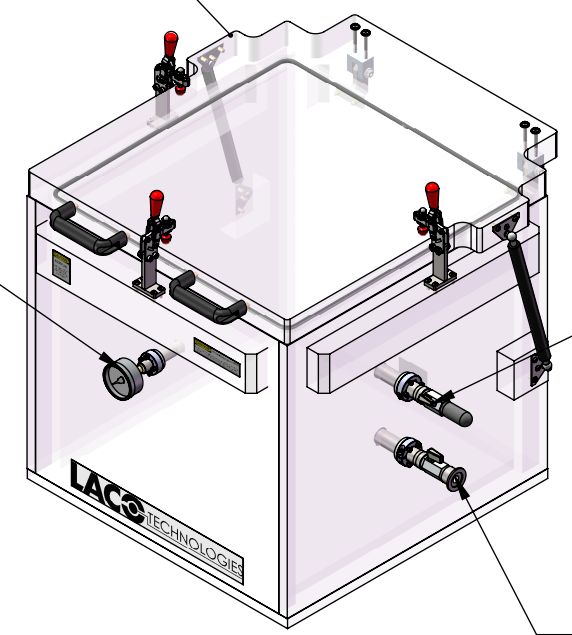

1/4" NPT VENT PORT W/ BALL VALVE AND MUFFLER

1/2" NPT PORT W/ BALL VALVE AND NW25 ADAPTER

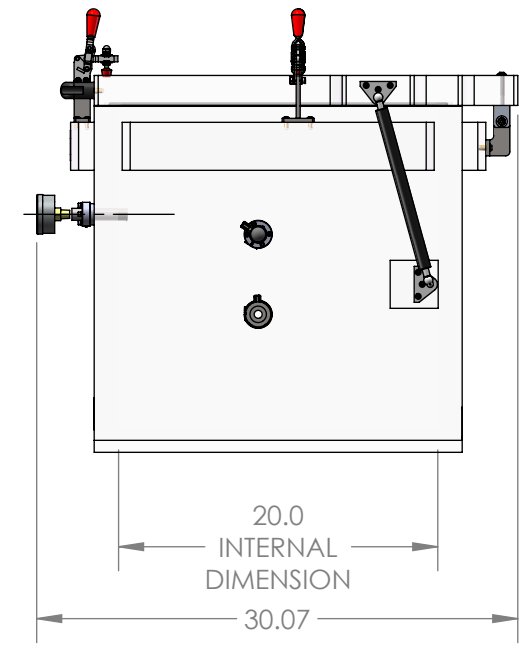
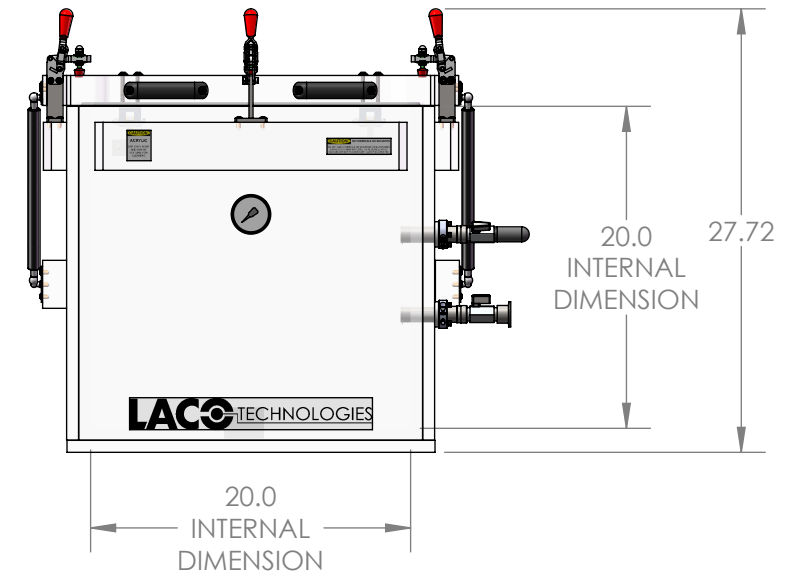

NOTES:  
1. ESTIMATED SYSTEM WEIGHT: 221 lbs



**UNLESS OTHERWISE SPECIFIED:**  
DIMENSIONS ARE IN INCHES.  
TOLERANCES:  
FRACTIONAL: ±1/16"  
ANGULAR: MACH ±1° / BEND ±2°  
TWO PLACE DECIMAL: ±.03  
THREE PLACE DECIMAL: ±.005  
GEOMETRIC TOLERANCING PER  
ASME Y14.5M - 2009

**CHAMBER, 20" X 20" CUBE  
HINGED LID, ACRYLIC  
STANDARD PORTS**

**PROPRIETARY AND CONFIDENTIAL**  
THE INFORMATION CONTAINED IN THIS  
DRAWING IS THE SOLE PROPERTY OF LACO  
TECHNOLOGIES, INC. ANY  
REPRODUCTION IN PART OR AS A WHOLE  
WITHOUT THE WRITTEN PERMISSION OF  
LACO TECHNOLOGIES, INC., IS PROHIBITED.

DRAWN BY	NAME	DATE
SEE ABAS FOR APPROVER	JRA	2/13/2018
DWG. NO.	REV	
112707-C	A	
SCALE: 1:12	SIZE: B	SHEET 1 OF 1