

REV.	LCO No.	REV DESCRIPTION	DATE	APPROVED
A	1252	INITIAL RELEASE	1/29/18	MLC

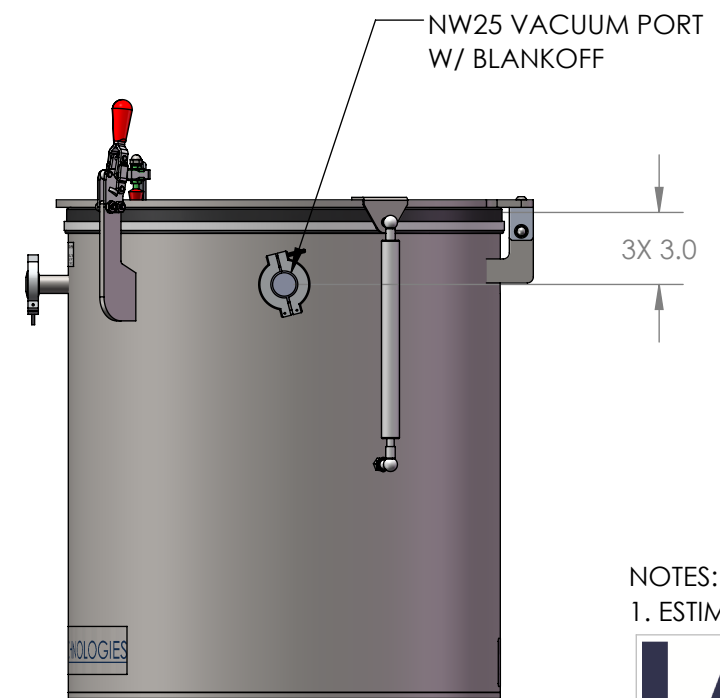

NOTES:
1. ESTIMATED SYSTEM WEIGHT: 114.0 lbs

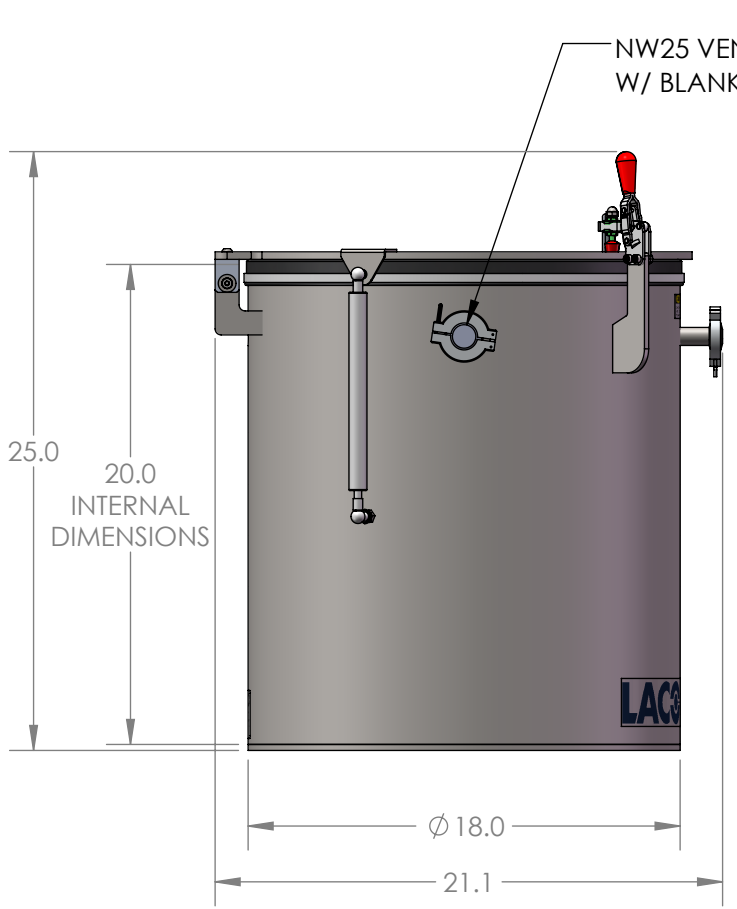
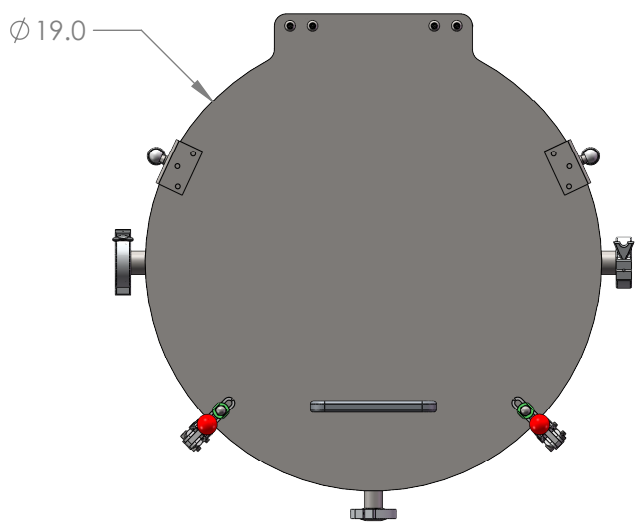

UNLESS OTHERWISE SPECIFIED:
DIMENSIONS ARE IN INCHES.
TOLERANCES:
FRACTIONAL: ±1/16"
ANGULAR: MACH ±1° / BEND ±2°
TWO PLACE DECIMAL: ±.03
THREE PLACE DECIMAL: ±.005
GEOMETRIC TOLERANCING PER
ASME Y14.5M - 2009

PROPRIETARY AND CONFIDENTIAL
THE INFORMATION CONTAINED IN THIS
DRAWING IS THE SOLE PROPERTY OF LACO
TECHNOLOGIES, INC. ANY
REPRODUCTION IN PART OR AS A WHOLE
WITHOUT THE WRITTEN PERMISSION OF
LACO TECHNOLOGIES, INC., IS PROHIBITED.

18" X 20" VERTICAL CHAMBER,
SS BODY, SS HINGED LID,
STD PORTS

DRAWN BY	NAME	DATE
JRA	JRA	1/29/18
SEE ABAS FOR APPROVER		
DWG. NO.	REV	
112569-C	A	
SCALE: 1:12	SIZE: B	SHEET 1 OF 1