

REV.	LCO No.	DESCRIPTION	DATE	APPROVED
A	1252	INITIAL RELEASE	3/19/18	JRA

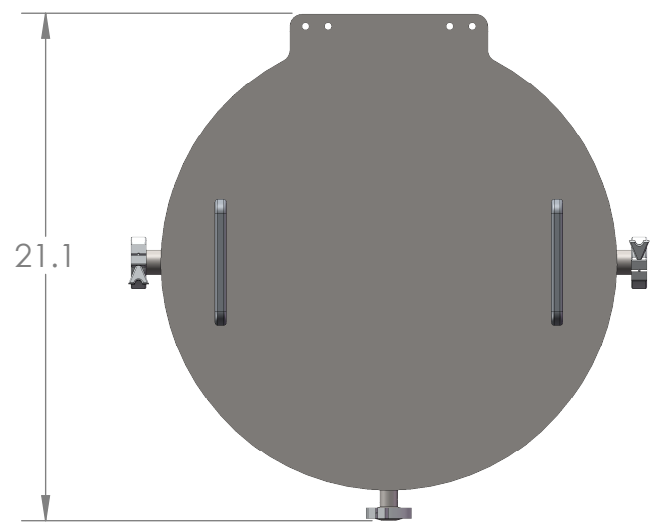

STAINLESS STEEL BODY AND LID

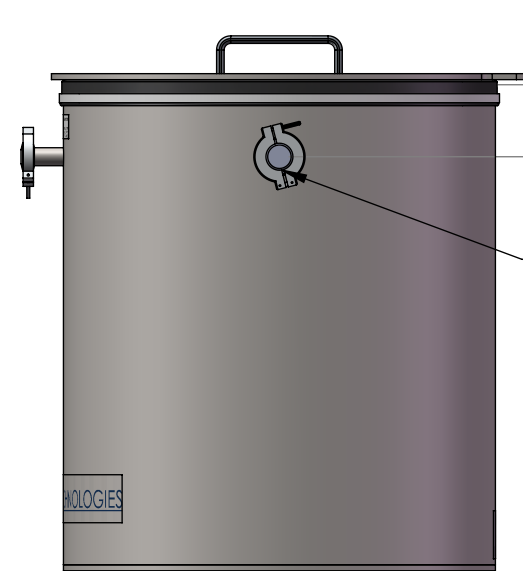
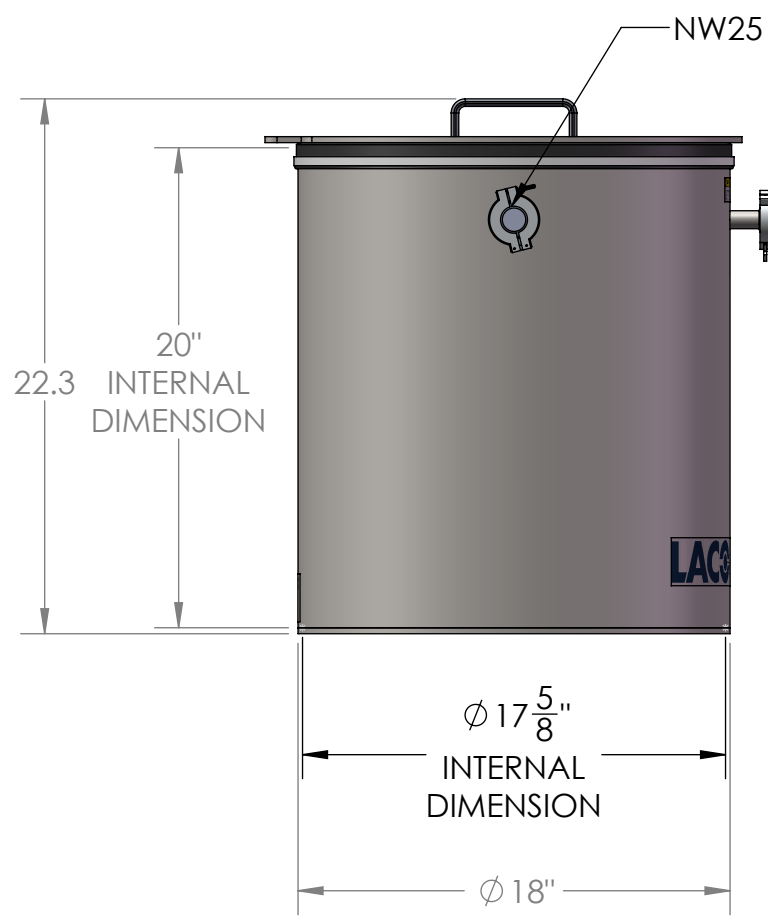

NOTES:
1. ESTIMATED SYSTEM WEIGHT: 109 LBS



UNLESS OTHERWISE SPECIFIED:
DIMENSIONS ARE IN INCHES.
TOLERANCES:
FRACTIONAL: ±1/16"
ANGULAR: MACH ±1° / BEND ±2°
ONE PLACE DECIMAL: ±.05
TWO PLACE DECIMAL: ±.01
THREE PLACE DECIMAL: ±.005
GEO TOLERANCING: ASME Y14.5M - 2009

PROPRIETARY AND CONFIDENTIAL
THE INFORMATION CONTAINED IN THIS DRAWING IS THE SOLE PROPERTY OF LACO TECHNOLOGIES, INC. ANY REPRODUCTION IN PART OR AS A WHOLE WITHOUT THE WRITTEN PERMISSION OF LACO TECHNOLOGIES, INC., IS PROHIBITED.

CHAMBER, VERTICAL 18" X 20", 304SS, HIGH VAC STANDARD PORTS		
DRAWN BY	NAME	DATE
SEE ABAS FOR APPROVER	JRA	1/26/18
DWG. NO.	REV	
112555-C	A	
SCALE: 1:8	SIZE: B	SHEET 1 OF 1

8 7 6 5 4 3 2 1

D
C
B
A

D
C
B
A

8 7 6 5 4 3 2 1