

REV.	LCO No.	DESCRIPTION	DATE	APPROVED
A	1252	INITIAL RELEASE	5/8/18	JRA

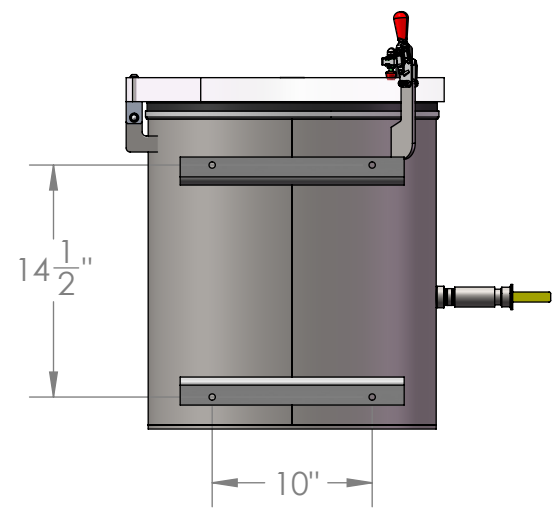

NOTES:
1. ESTIMATED SYSTEM WEIGHT: 117 lbs

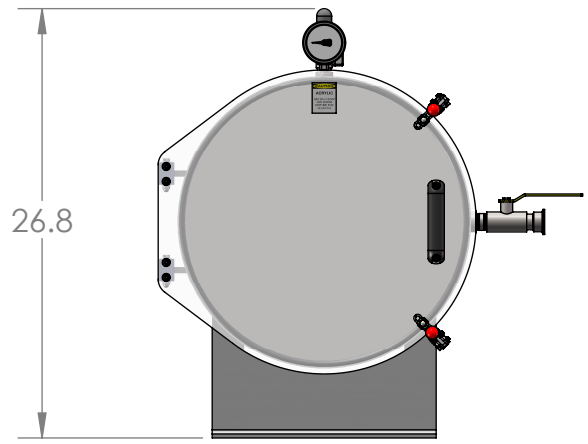
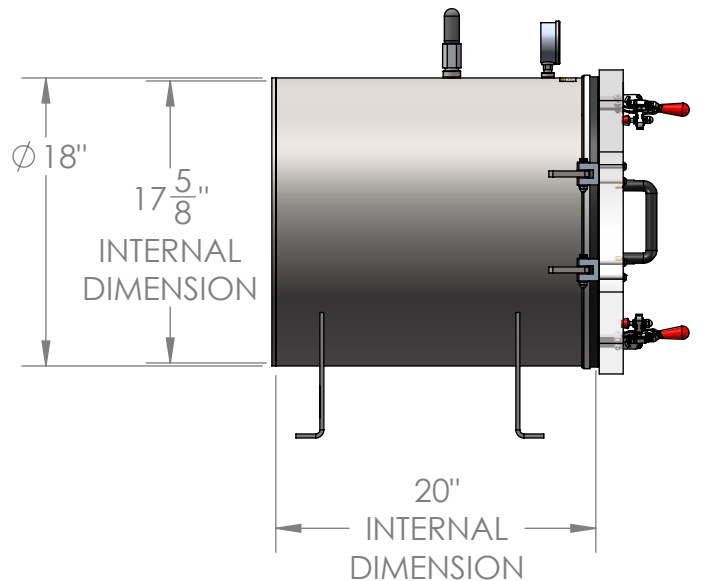
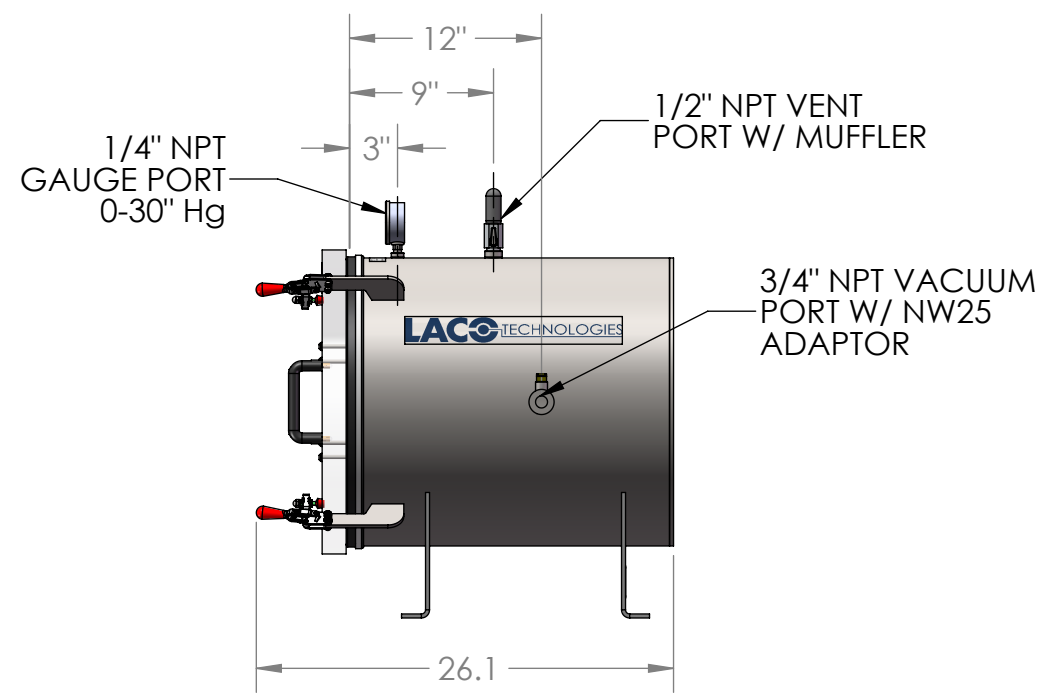
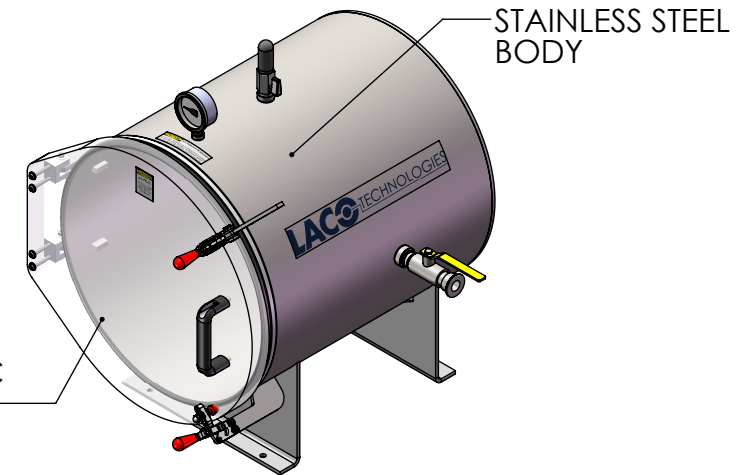
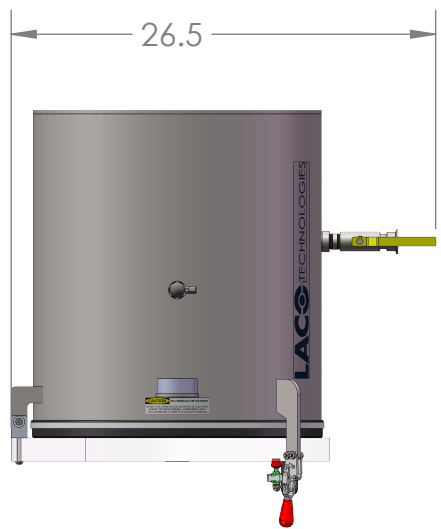

<p>UNLESS OTHERWISE SPECIFIED: DIMENSIONS ARE IN INCHES. TOLERANCES: FRACTIONAL: ±1/16" ANGULAR: MACH ±1° / BEND ±2° ONE PLACE DECIMAL: ±.05 TWO PLACE DECIMAL: ±.01 THREE PLACE DECIMAL: ±.005 GEO TOLERANCING: ASME Y14.5M - 2009</p>		
<p>CHAMBER, EXPRESS, 18" X 20" HORIZONTAL, 304SS, ACRYLIC LID STANDARD PORTS</p>		
<p>PROPRIETARY AND CONFIDENTIAL THE INFORMATION CONTAINED IN THIS DRAWING IS THE SOLE PROPERTY OF LACO TECHNOLOGIES, INC. ANY REPRODUCTION IN PART OR AS A WHOLE WITHOUT THE WRITTEN PERMISSION OF LACO TECHNOLOGIES, INC., IS PROHIBITED.</p>	<p>DRAWN BY SEE ABAS FOR APPROVER</p>	<p>NAME JRA</p> <p>DATE 1/23/18</p>
<p>DWG. NO. 112529-C</p>	<p>SCALE: 1:12</p>	<p>REV A</p> <p>SHEET 1 OF 1</p>