

REV.	LCO No.	DESCRIPTION	DATE	APPROVED
A	1252	INITIAL RELEASE	3/14/2018	JRA
B	1531	CHANGED VACUUM PORT FROM 3/4 NPT TO NW25	4/9/2020	BHD

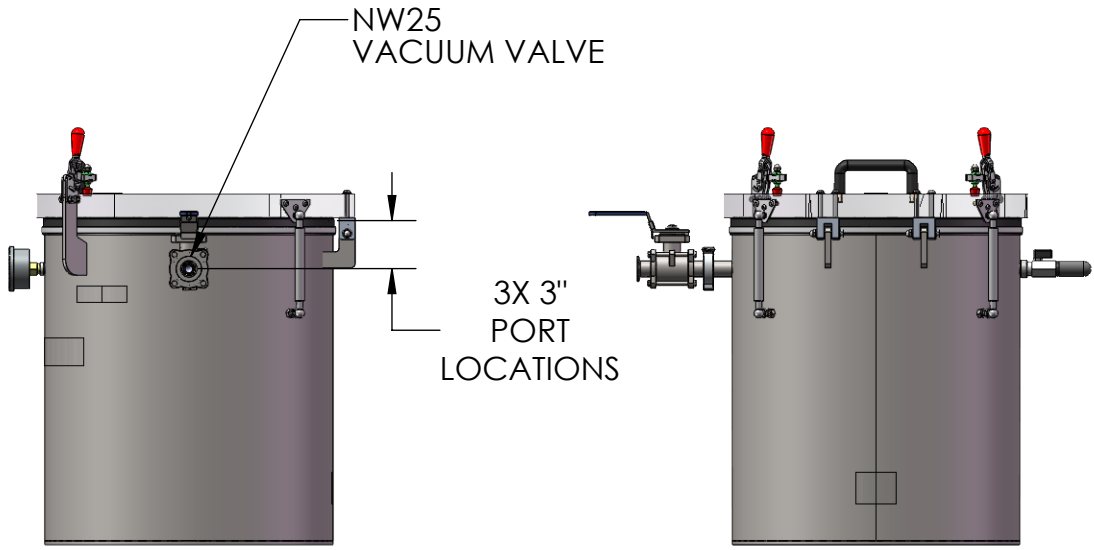

NOTES:
1. ESTIMATED SYSTEM WEIGHT: 110 LB.

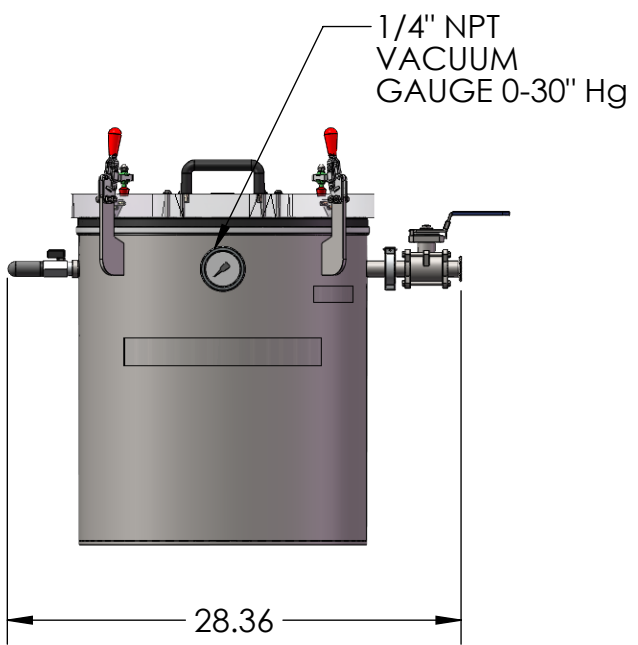
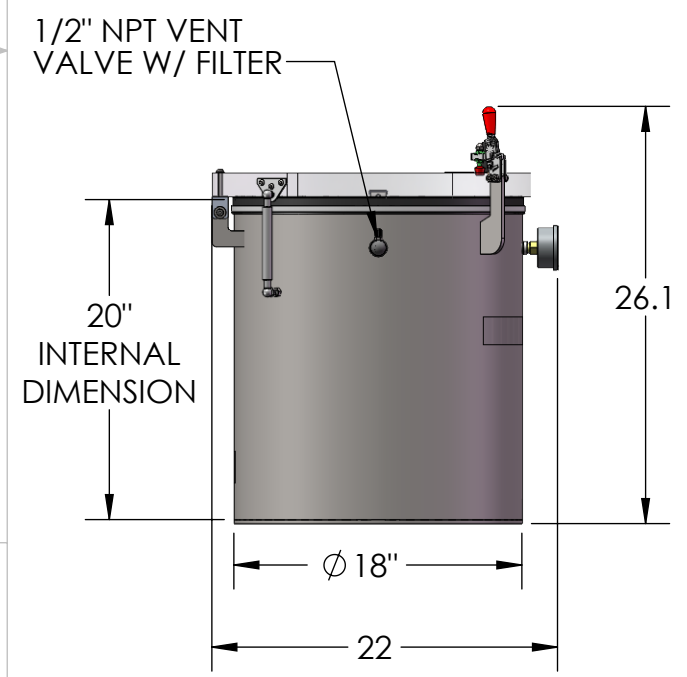
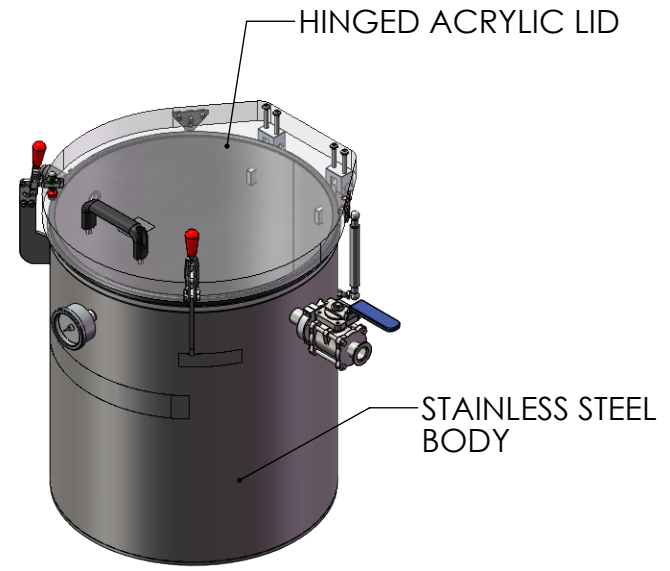
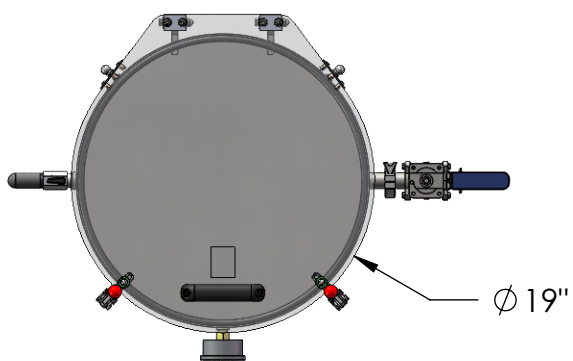

UNLESS OTHERWISE SPECIFIED: DIMENSIONS ARE IN INCHES. TOLERANCES: FRACTIONAL: ±1/16" ANGULAR: MACH ±1° / BEND ±2° ONE PLACE DECIMAL: ±.05 TWO PLACE DECIMAL: ±.01 THREE PLACE DECIMAL: ±.005 GEO TOLERANCING: ASME Y14.5M - 2009		18" X 20" SS CHAMBER ACRYLIC HINGED LID STANDARD PORTS	
DRAWN BY	NAME	DATE	
SEE ABAS FOR APPROVER	JRA	1/23/18	
DWG. NO.	112538-C		REV B
SCALE: 1:12	SIZE: B	SHEET 1 OF 1	

8 7 6 5 4 3 2 1

8 7 6 5 4 3 2 1