

REV.	LCO No.	DESCRIPTION	DATE	APPROVED
A	1252	INITIAL RELEASE	3/1/2018	JRA

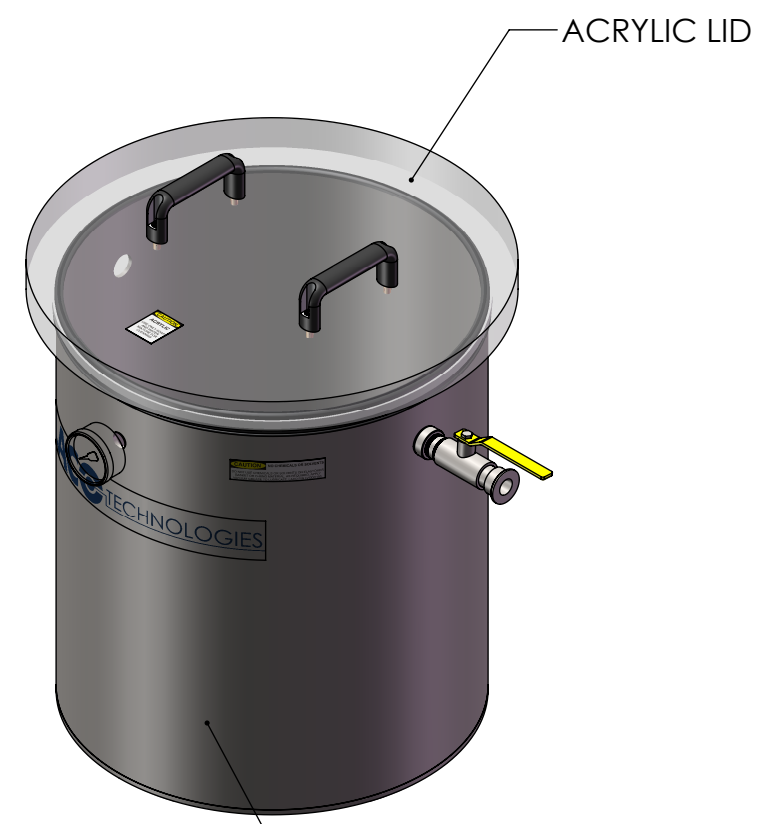
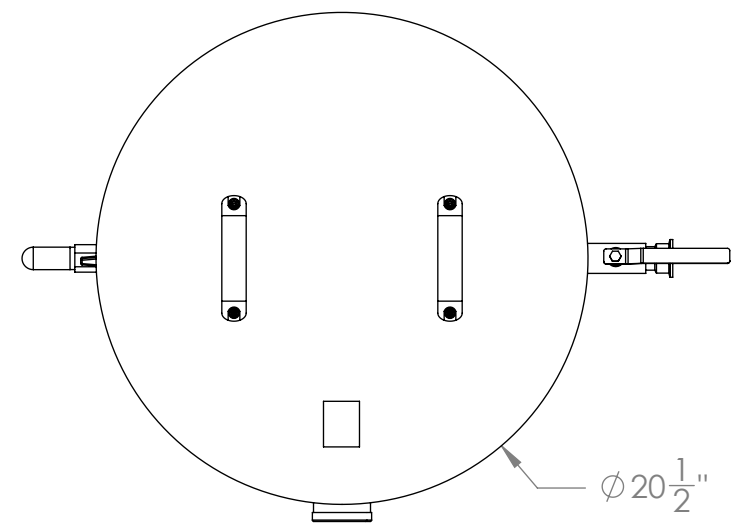

1/2" NPT VENT VALVE W/ MUFFLER

3/4" NPT VACUUM VALVE W/ NW25 ADAPTER

1/4 NPT VACUUM GAUGE, 0-30" HG

304 STAINLESS STEEL BODY

3X 3" PORT LOCATION

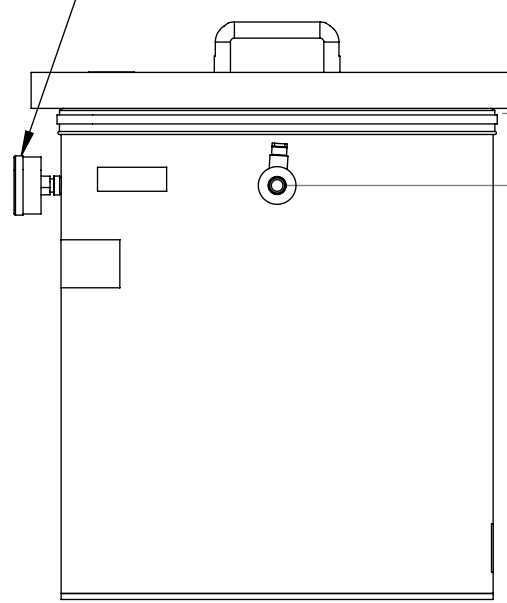
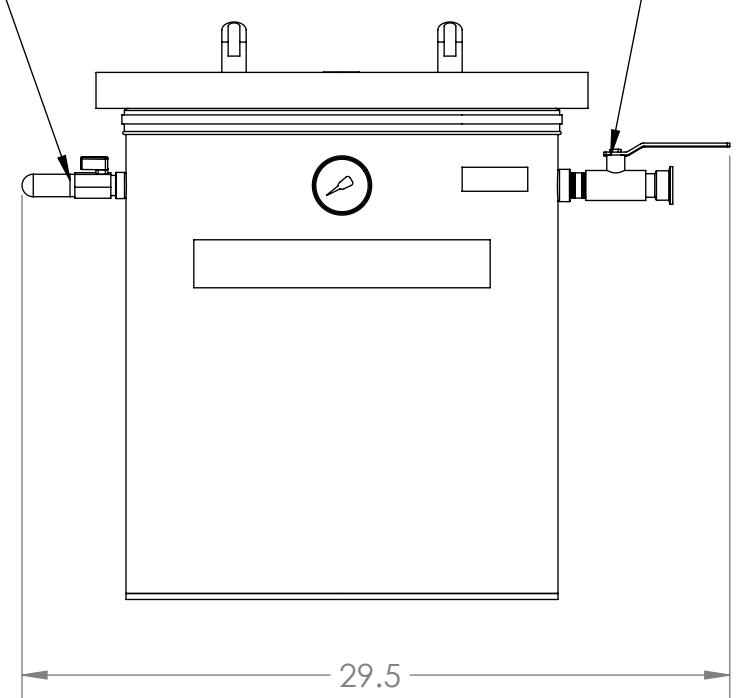
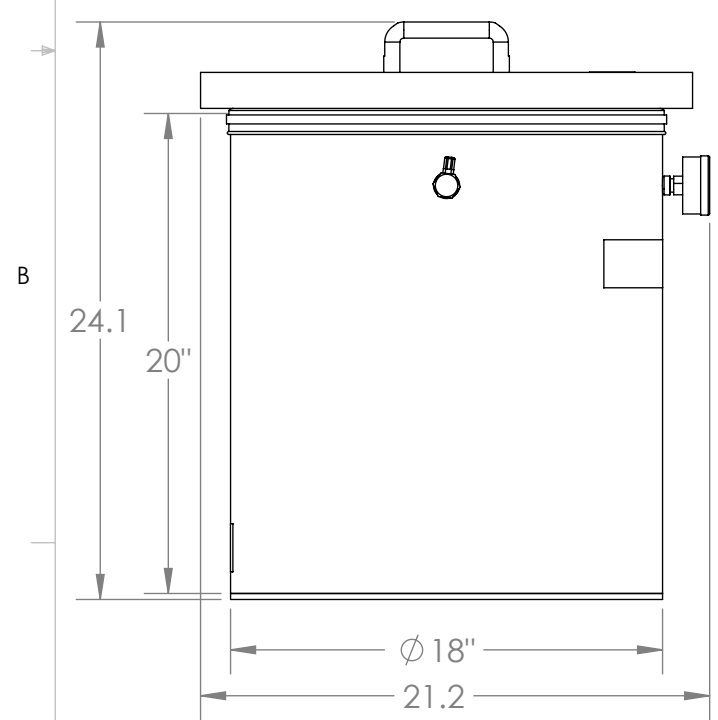

NOTES:  
1. ESTIMATED SYSTEM WEIGHT: 110 lbs



UNLESS OTHERWISE SPECIFIED: DIMENSIONS ARE IN INCHES. TOLERANCES: FRACTIONAL: $\pm 1/16$ " ANGULAR: MACH $\pm 1^\circ$ / BEND $\pm 2^\circ$ TWO PLACE DECIMAL: $\pm .03$ THREE PLACE DECIMAL: $\pm .005$ GEOMETRIC TOLERANCING PER ASME Y14.5M - 2009			18" X 20" VERTICAL SS CHAMBER WITH REMOVABLE LID		
PROPRIETARY AND CONFIDENTIAL THE INFORMATION CONTAINED IN THIS DRAWING IS THE SOLE PROPERTY OF LACO TECHNOLOGIES, INC. ANY REPRODUCTION IN PART OR AS A WHOLE WITHOUT THE WRITTEN PERMISSION OF LACO TECHNOLOGIES, INC., IS PROHIBITED.					
DRAWN BY		NAME	DATE		
APPROVED BY		JRA	22 JAN 2018		
DWG. NO.			REV		
112525-C			A		
SCALE: 1:8		SIZE: B	SHEET 1 OF 1		