

REV.	LCO No.	DESCRIPTION	DATE	APPROVED
A	1252	INITIAL RELEASE	6/19/2018	ABS

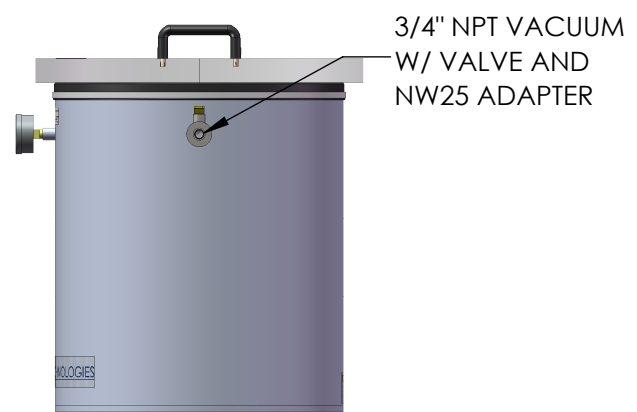
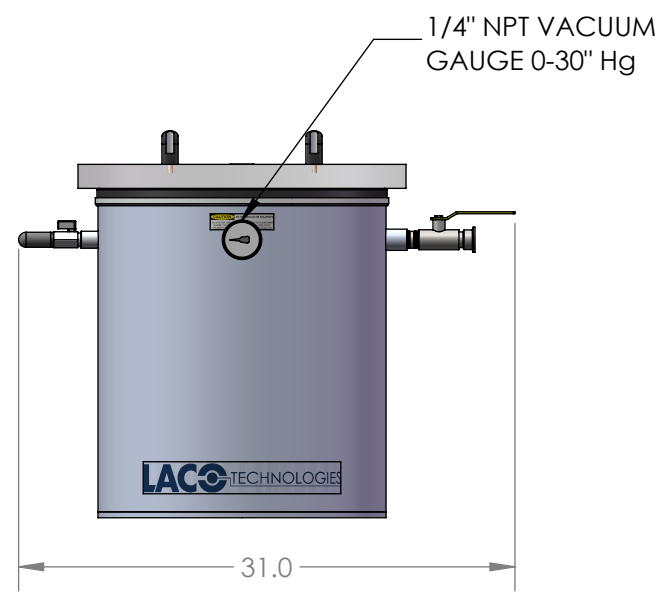
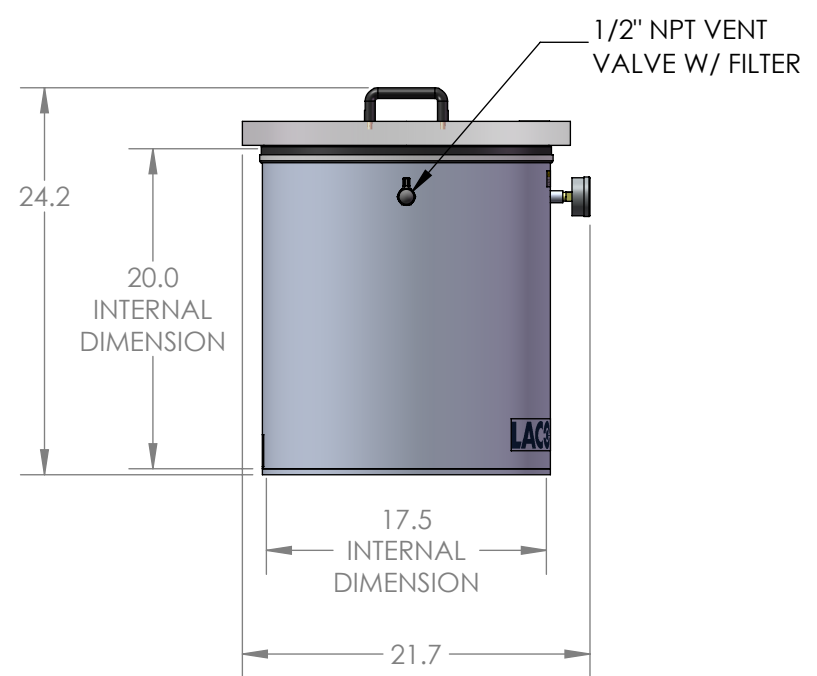
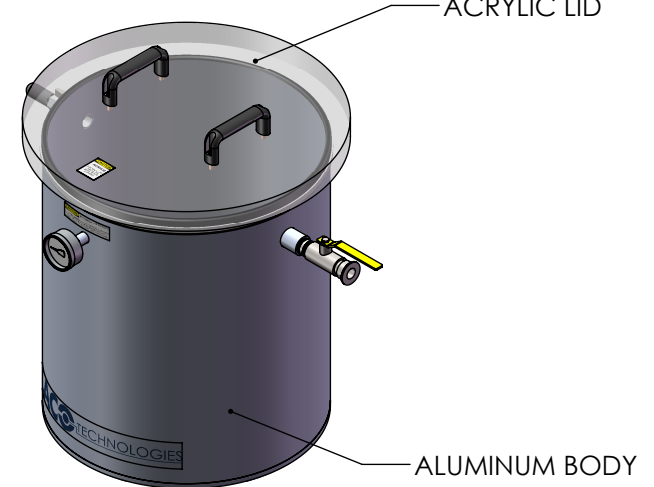
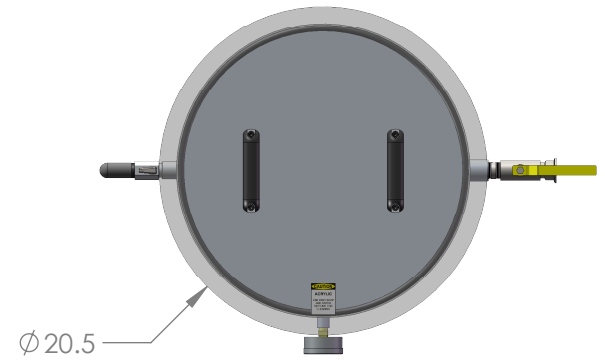

NOTES:
1. ESTIMATED SYSTEM WEIGHT: 65 lbs

LACO TECHNOLOGIES

UNLESS OTHERWISE SPECIFIED:
DIMENSIONS ARE IN INCHES.
TOLERANCES:
FRACTIONAL: ±1/16"
ANGULAR: MACH ±1° / BEND ±2°
TWO PLACE DECIMAL: ±.03
THREE PLACE DECIMAL: ±.005
GEOMETRIC TOLERANCING PER ASME Y14.5M - 2009

CHAMBER, EXPRESS, 18" X 20" VERTICAL, ALUMINUM STANDARD PORTS

DRAWN BY	NAME	DATE
JRA	JRA	3/29/18

SEE ABAS FOR APPROVER

DWG. NO. **112540-C** REV **A**

SCALE: 1:12 SIZE: B SHEET 1 OF 1

PROPRIETARY AND CONFIDENTIAL
THE INFORMATION CONTAINED IN THIS DRAWING IS THE SOLE PROPERTY OF LACO TECHNOLOGIES, INC. ANY REPRODUCTION IN PART OR AS A WHOLE WITHOUT THE WRITTEN PERMISSION OF LACO TECHNOLOGIES, INC., IS PROHIBITED.