

REV.	LCO No.	REV DESCRIPTION	DATE	APPROVED
A	1255	INITIAL RELEASE	5/8/18	JRA

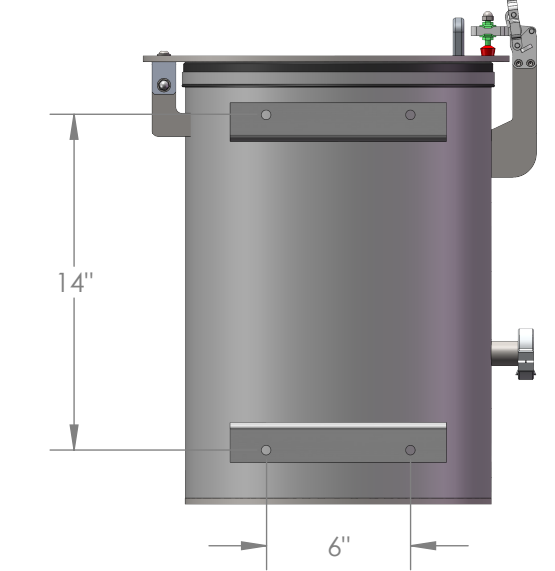

NOTES:  
1. ESTIMATED SYSTEM WEIGHT: 67 lbs

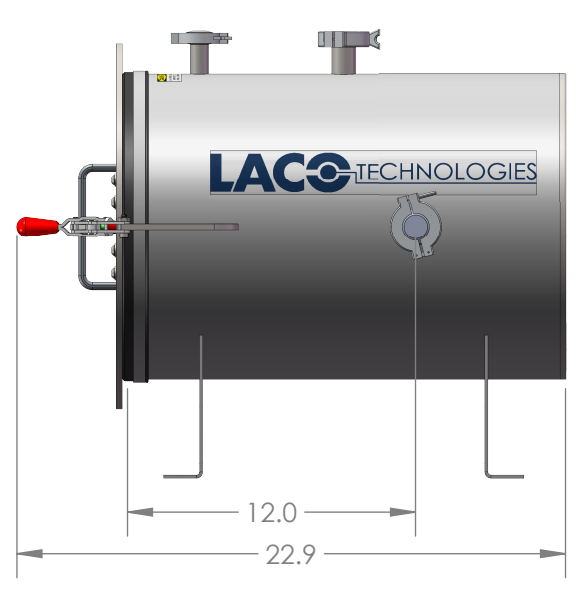
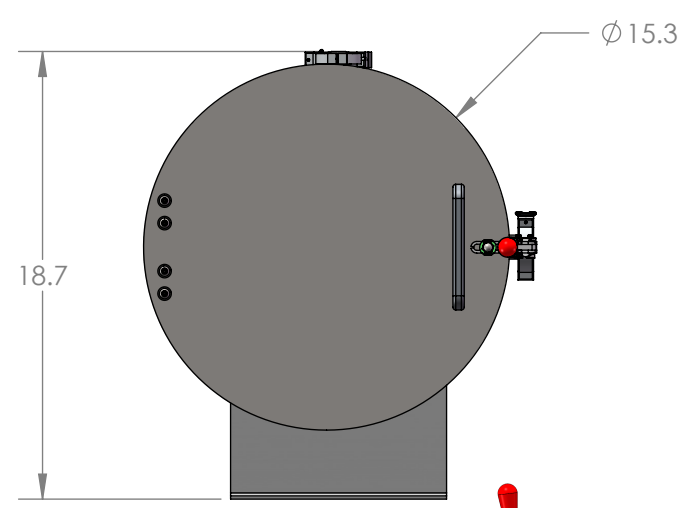
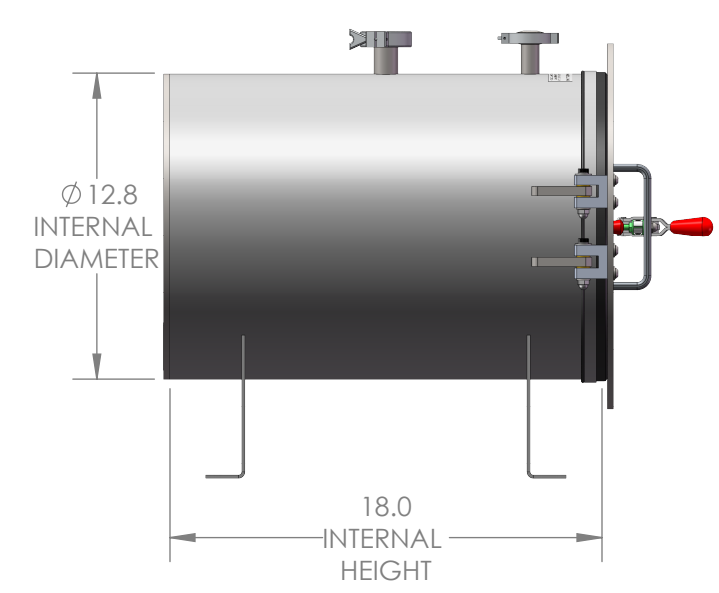
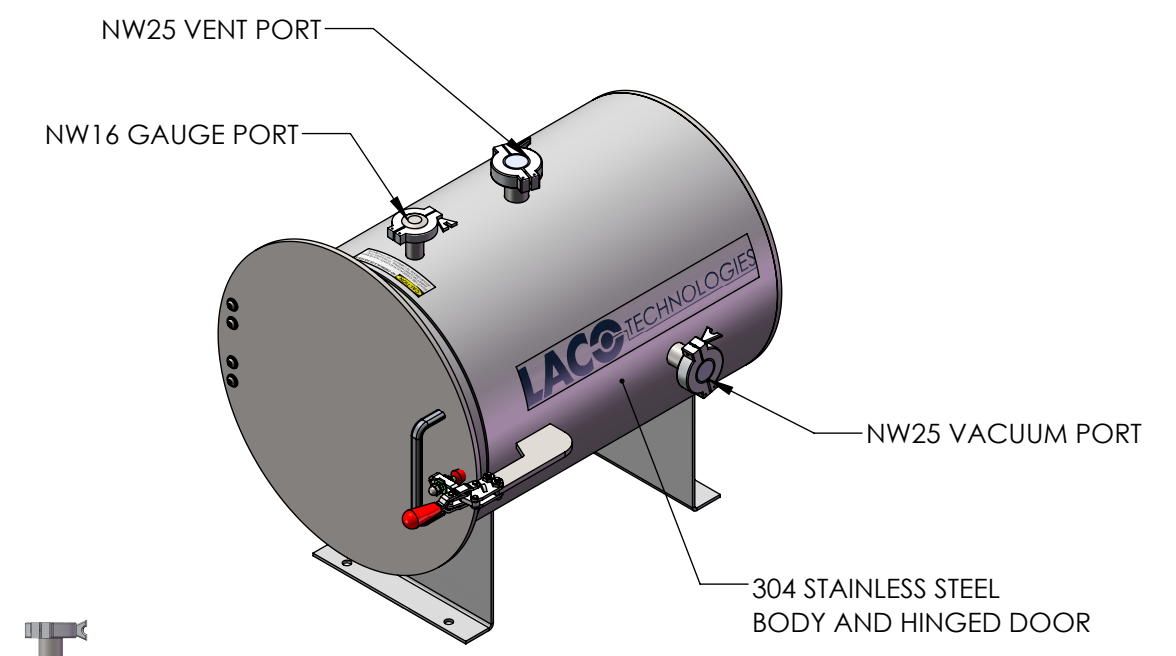
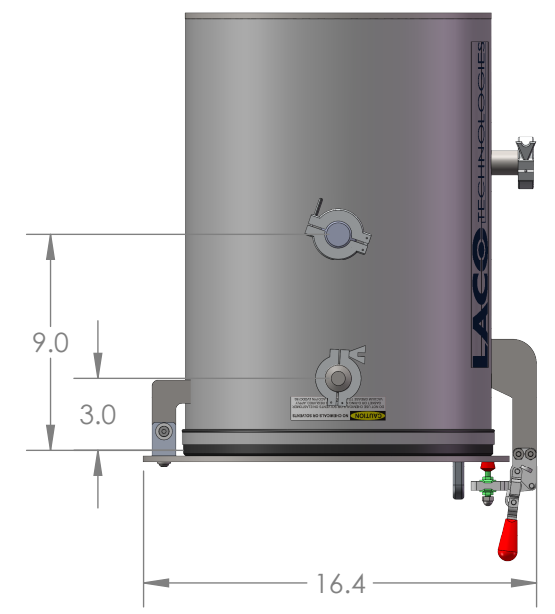

**UNLESS OTHERWISE SPECIFIED:**  
DIMENSIONS ARE IN INCHES.  
TOLERANCES:  
FRACTIONAL: ±1/16"  
ANGULAR: MACH ±1° / BEND ±2°  
TWO PLACE DECIMAL: ±.03  
THREE PLACE DECIMAL: ±.005  
GEOMETRIC TOLERANCING PER  
ASME Y14.5M - 2009

**PROPRIETARY AND CONFIDENTIAL**  
THE INFORMATION CONTAINED IN THIS  
DRAWING IS THE SOLE PROPERTY OF LACO  
TECHNOLOGIES, INC. ANY  
REPRODUCTION IN PART OR AS A WHOLE  
WITHOUT THE WRITTEN PERMISSION OF  
LACO TECHNOLOGIES, INC., IS PROHIBITED.

<b>12" X 18" HOR, SS BODY, SS LID, HIGH VAC, STANDARD PORTS</b>		
DRAWN BY	NAME	DATE
SEE ABAS FOR APPROVER	JRA	2/6/18
DWG. NO.	REV	
<b>112665-C</b>	<b>A</b>	
SCALE: 1:8	SIZE: B	SHEET 1 OF 1