

REV.	LCO No.	REV DESCRIPTION	DATE	APPROVED
A	1255	INITIAL RELEASE	5/8/18	JRA

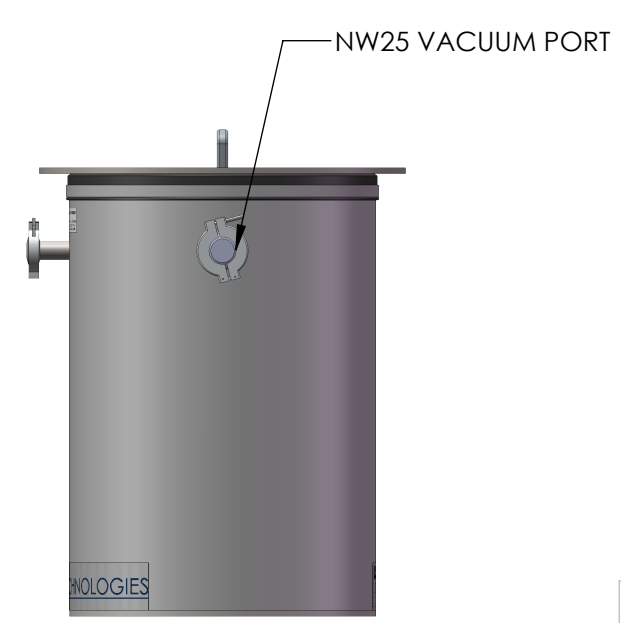

NOTES:
1. ESTIMATED SYSTEM WEIGHT: 61.0 lbs

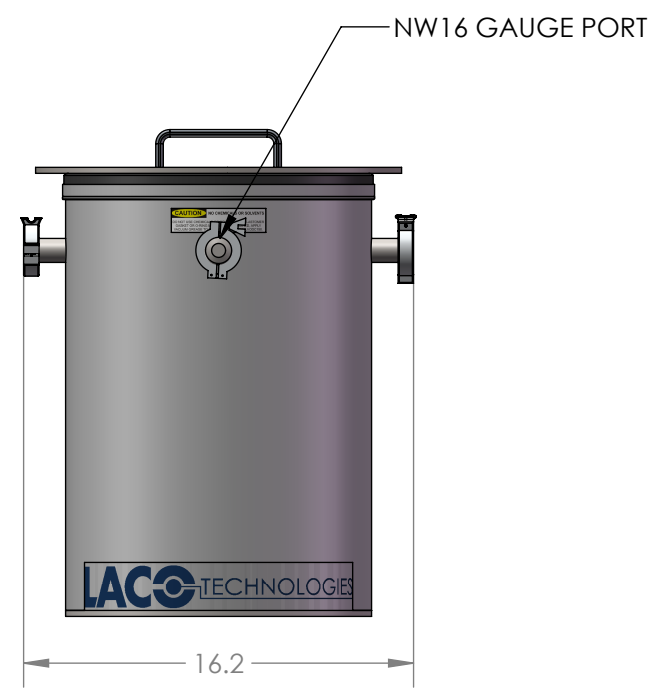
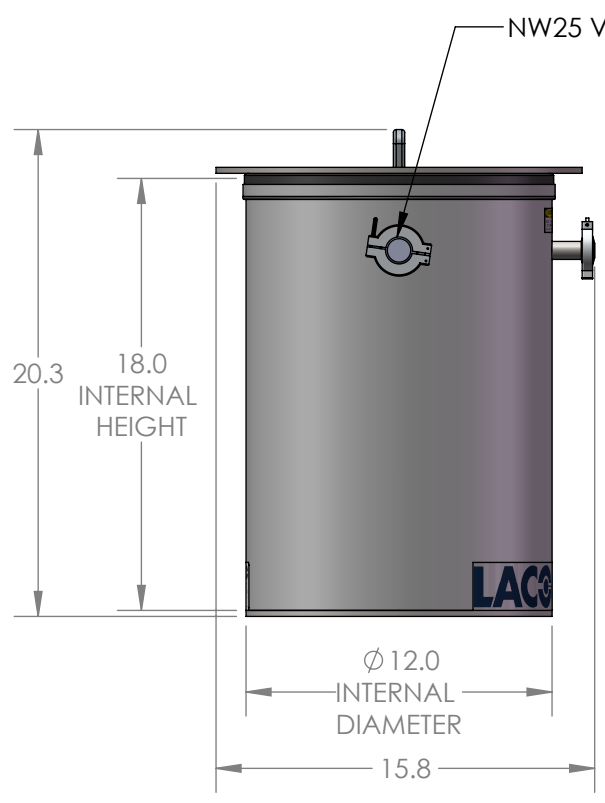
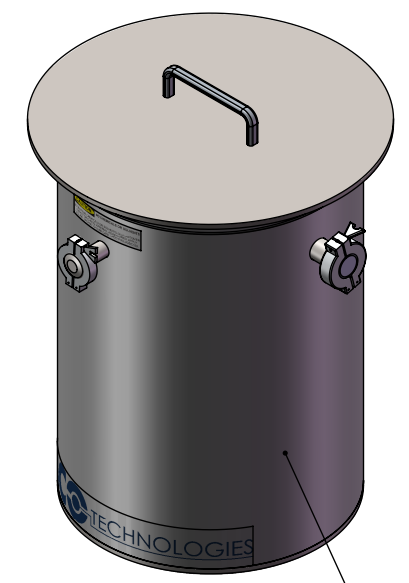
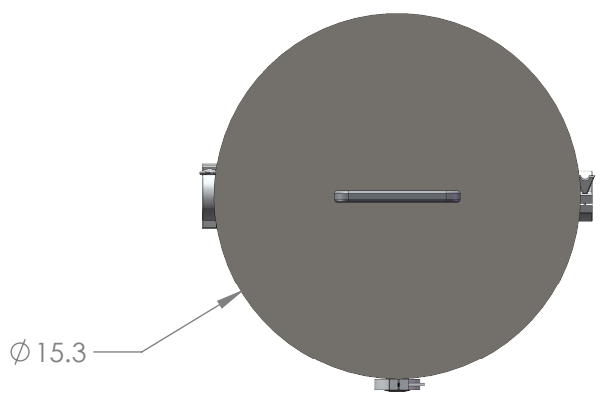

UNLESS OTHERWISE SPECIFIED:
DIMENSIONS ARE IN INCHES.
TOLERANCES:
FRACTIONAL: ±1/16"
ANGULAR: MACH ±1° / BEND ±2°
TWO PLACE DECIMAL: ±.03
THREE PLACE DECIMAL: ±.005
GEOMETRIC TOLERANCING PER
ASME Y14.5M - 2009

**12" X 18" VERTICAL, SS,
REMOVABLE SS LID,
STANDARD PORTS, HIGH VAC**

PROPRIETARY AND CONFIDENTIAL
THE INFORMATION CONTAINED IN THIS
DRAWING IS THE SOLE PROPERTY OF LACO
TECHNOLOGIES, INC. ANY
REPRODUCTION IN PART OR AS A WHOLE
WITHOUT THE WRITTEN PERMISSION OF
LACO TECHNOLOGIES, INC., IS PROHIBITED.

DRAWN BY	NAME	DATE
SEE ABAS FOR APPROVER	JRA	2/6/18
DWG. NO.	REV	
112657-C	A	
SCALE: 1:8	SIZE: B	SHEET 1 OF 1