

| REV. | LCO No. | REV DESCRIPTION | DATE | APPROVED |
|------|---------|-----------------|---------|----------|
| A | 1255 | INITIAL RELEASE | 5/17/18 | MLC |

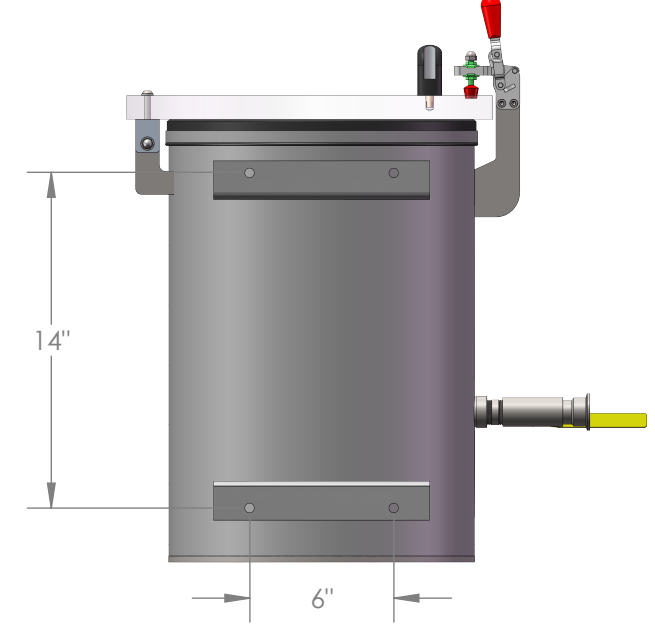

NOTES:
1. ESTIMATED SYSTEM WEIGHT: 63 lbs

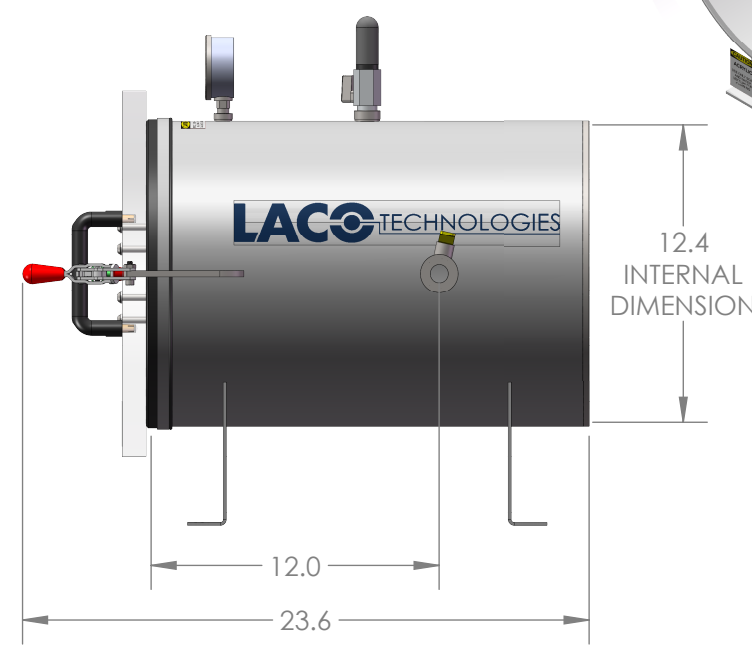
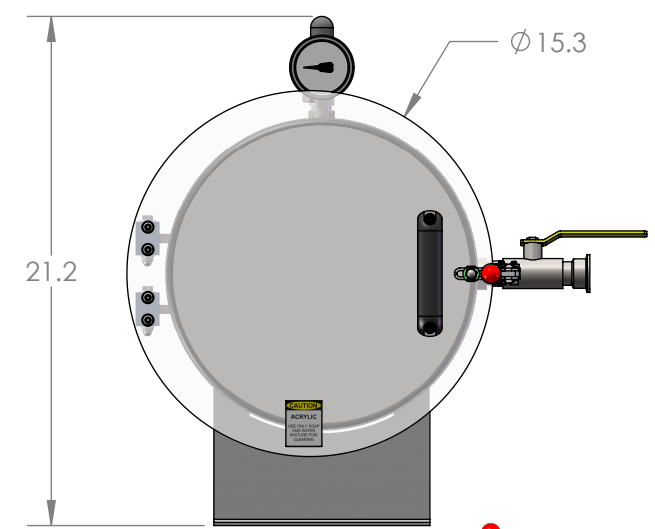
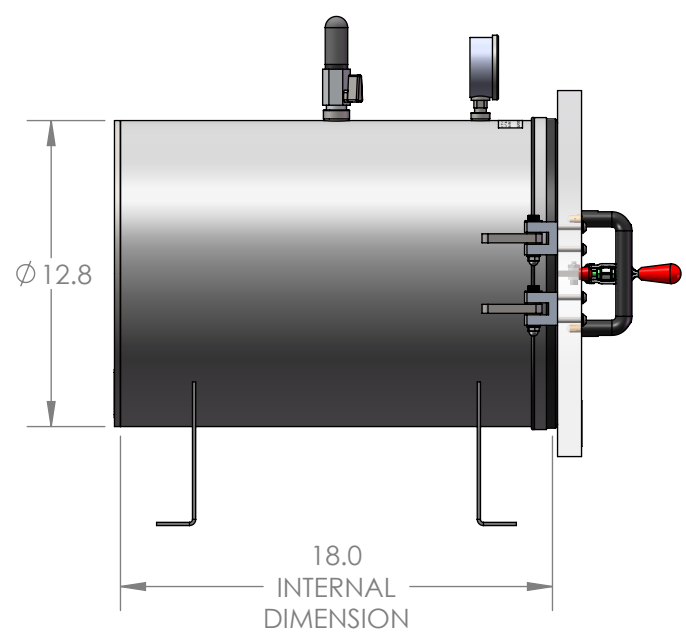
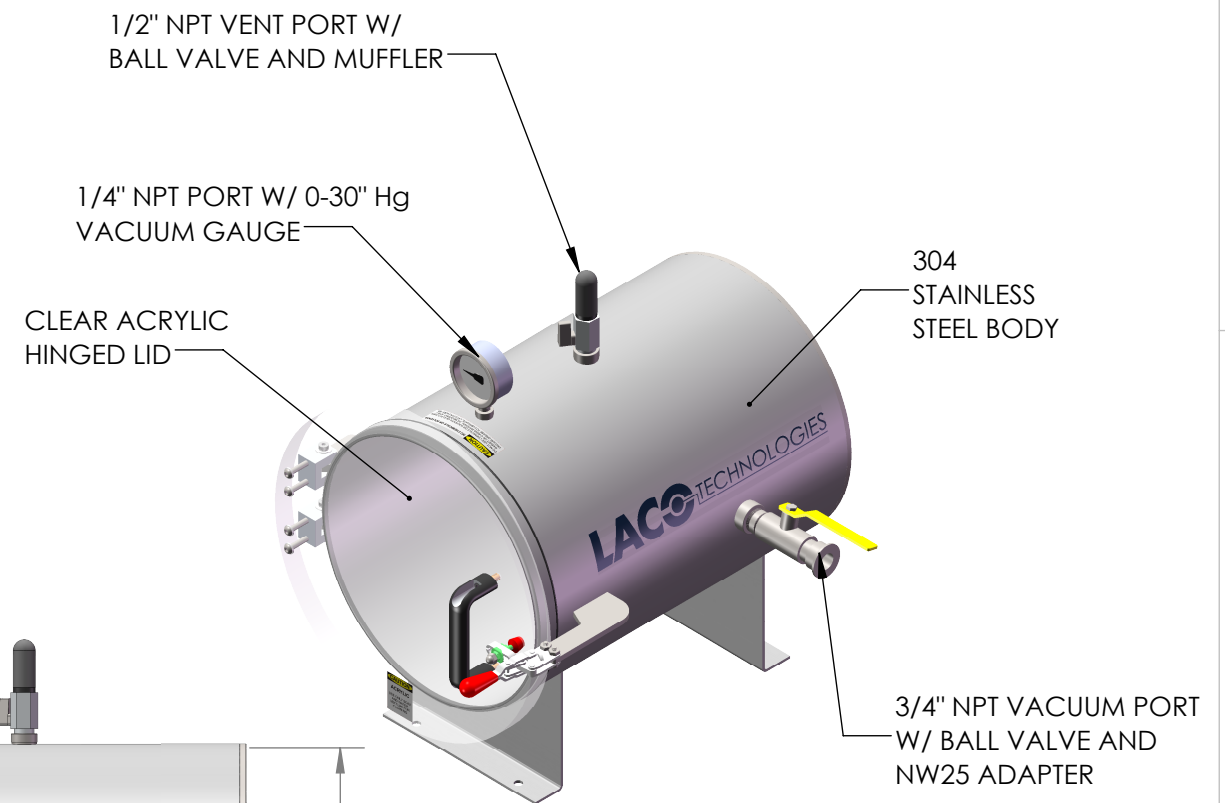
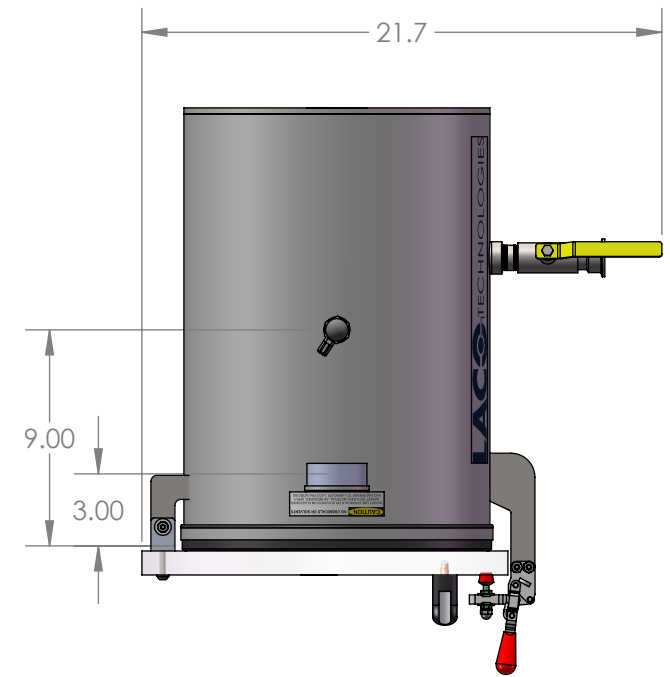

UNLESS OTHERWISE SPECIFIED:
DIMENSIONS ARE IN INCHES.
TOLERANCES:
FRACTIONAL: ±1/16"
ANGULAR: MACH ±1° / BEND ±2°
TWO PLACE DECIMAL: ±.03
THREE PLACE DECIMAL: ±.005
GEOMETRIC TOLERANCING PER
ASME Y14.5M - 2009

PROPRIETARY AND CONFIDENTIAL
THE INFORMATION CONTAINED IN THIS
DRAWING IS THE SOLE PROPERTY OF LACO
TECHNOLOGIES, INC. ANY
REPRODUCTION IN PART OR AS A WHOLE
WITHOUT THE WRITTEN PERMISSION OF
LACO TECHNOLOGIES, INC., IS PROHIBITED.

| | | |
|---|----------|--------------|
| 12" X 18" HORIZONTAL, SS BODY, ACR LID, STANDARD PORTS | | |
| DRAWN BY | NAME | DATE |
| SEE ABAS FOR APPROVER | JRA | 2/5/18 |
| DWG. NO. | REV | |
| 112647-C | A | |
| SCALE: 1:8 | SIZE: B | SHEET 1 OF 1 |