

REV.	LCO No.	REV DESCRIPTION	DATE	APPROVED
A	1254	INITIAL RELEASE	7/10/2018	ABS
B	1509	CHANGED PORT TYPE	01 May 2019	JRA

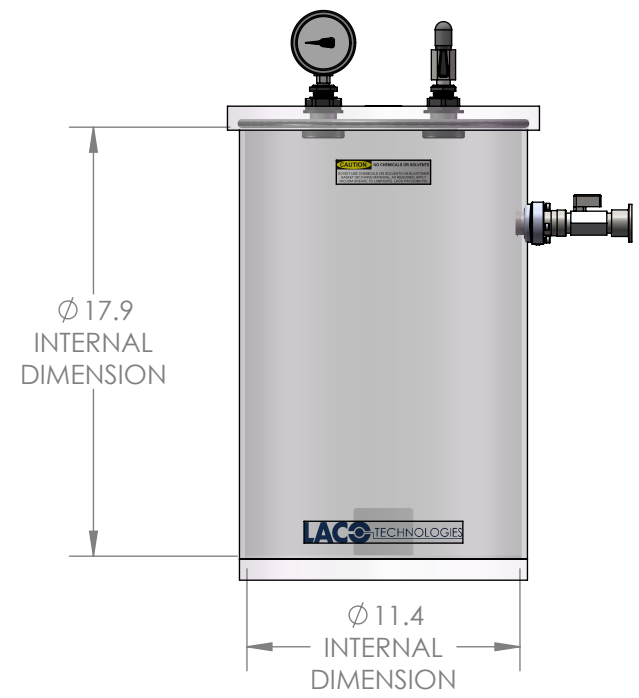

NOTES:
 1. ESTIMATED SYSTEM WEIGHT: 20 lbs

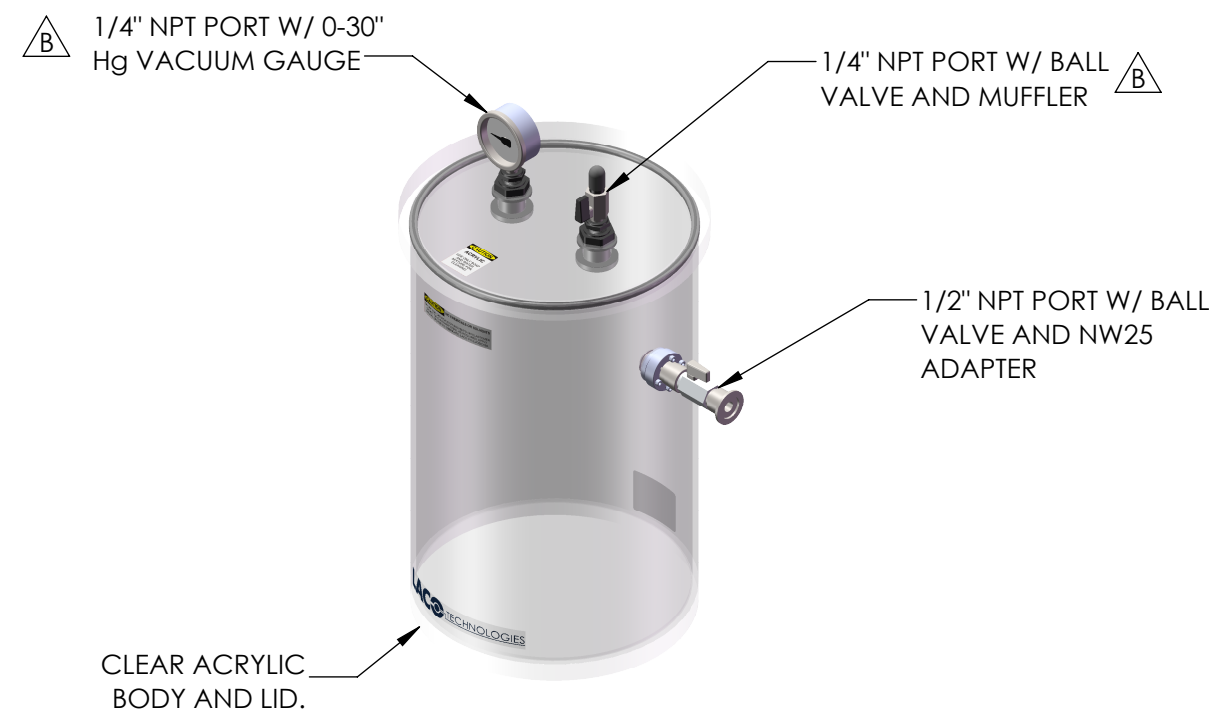
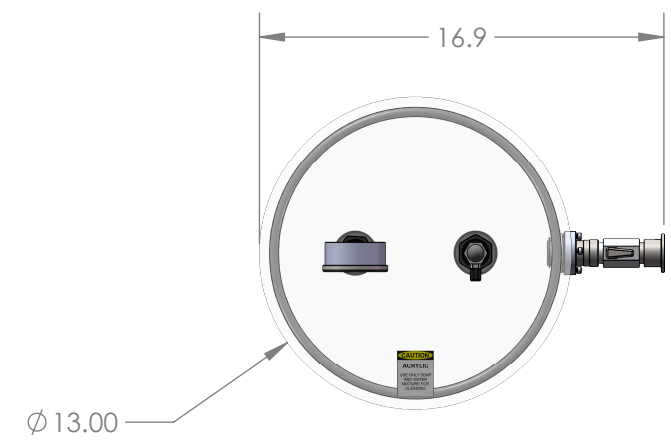

UNLESS OTHERWISE SPECIFIED:
 DIMENSIONS ARE IN INCHES.
 TOLERANCES:
 FRACTIONAL: $\pm 1/16"$
 ANGULAR: MACH $\pm 1^\circ$ / BEND $\pm 2^\circ$
 TWO PLACE DECIMAL: $\pm .03$
 THREE PLACE DECIMAL: $\pm .005$
 GEOMETRIC TOLERANCING PER ASME Y14.5M - 2009

CHAMBER, 12" X 18", VERTICAL ACRYLIC, REMOVABLE LID STANDARD PORTS

PROPRIETARY AND CONFIDENTIAL
 THE INFORMATION CONTAINED IN THIS DRAWING IS THE SOLE PROPERTY OF LACO TECHNOLOGIES, INC. ANY REPRODUCTION IN PART OR AS A WHOLE WITHOUT THE WRITTEN PERMISSION OF LACO TECHNOLOGIES, INC., IS PROHIBITED.

DRAWN BY	NAME	DATE
SEE ABAS FOR APPROVER	ABS	7/10/2018
DWG. NO.	REV	
112628-C	B	
SCALE: 1:8	SIZE: B	SHEET 1 OF 1