

CUSTOMER APPROVAL DRAWING
(Not for Manufacturing Use)

REV.	LCO No.	DESCRIPTION	DATE	APPROVED
A	1256	INITIAL RELEASE	17 APR 2018	JRA

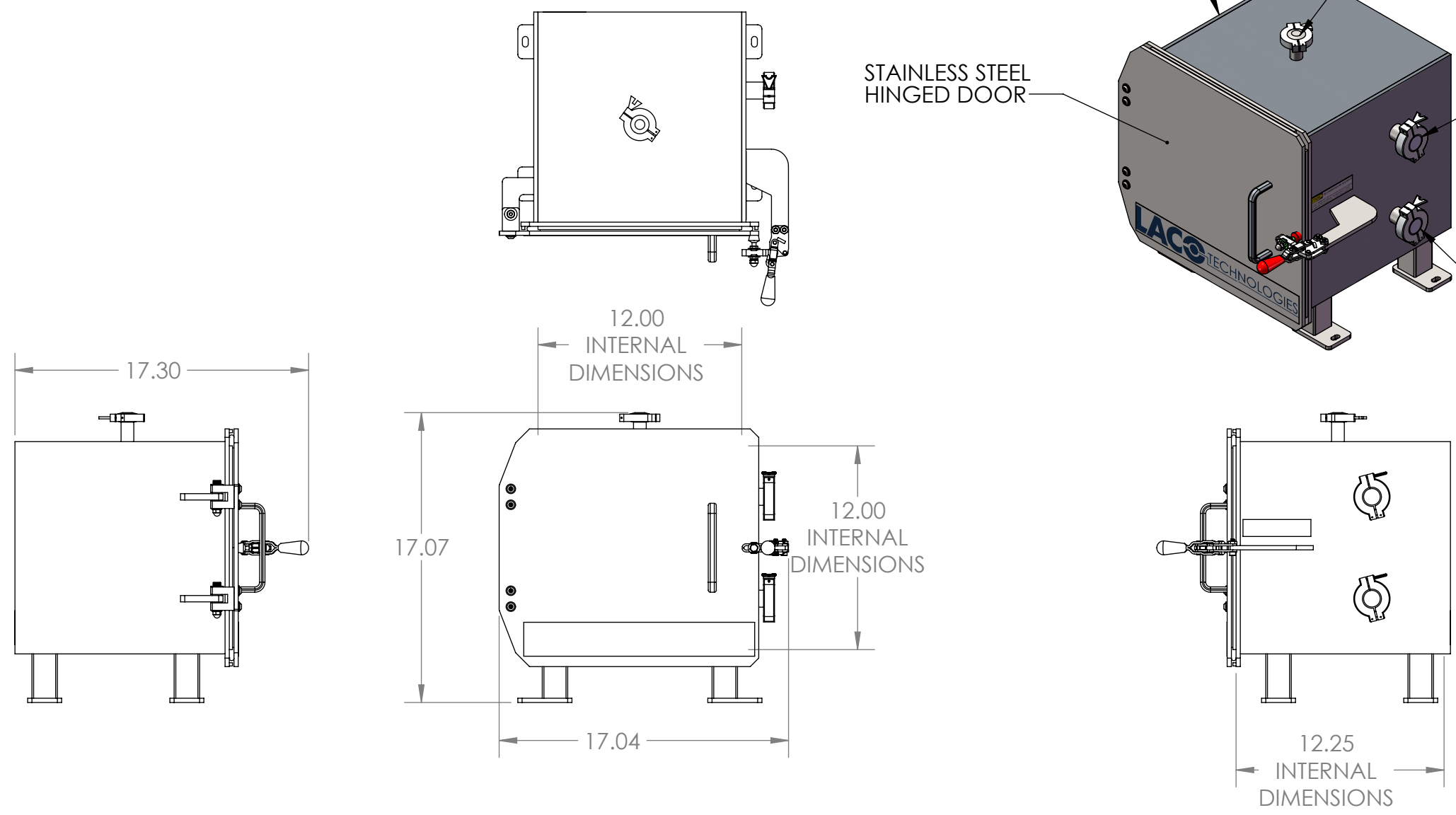
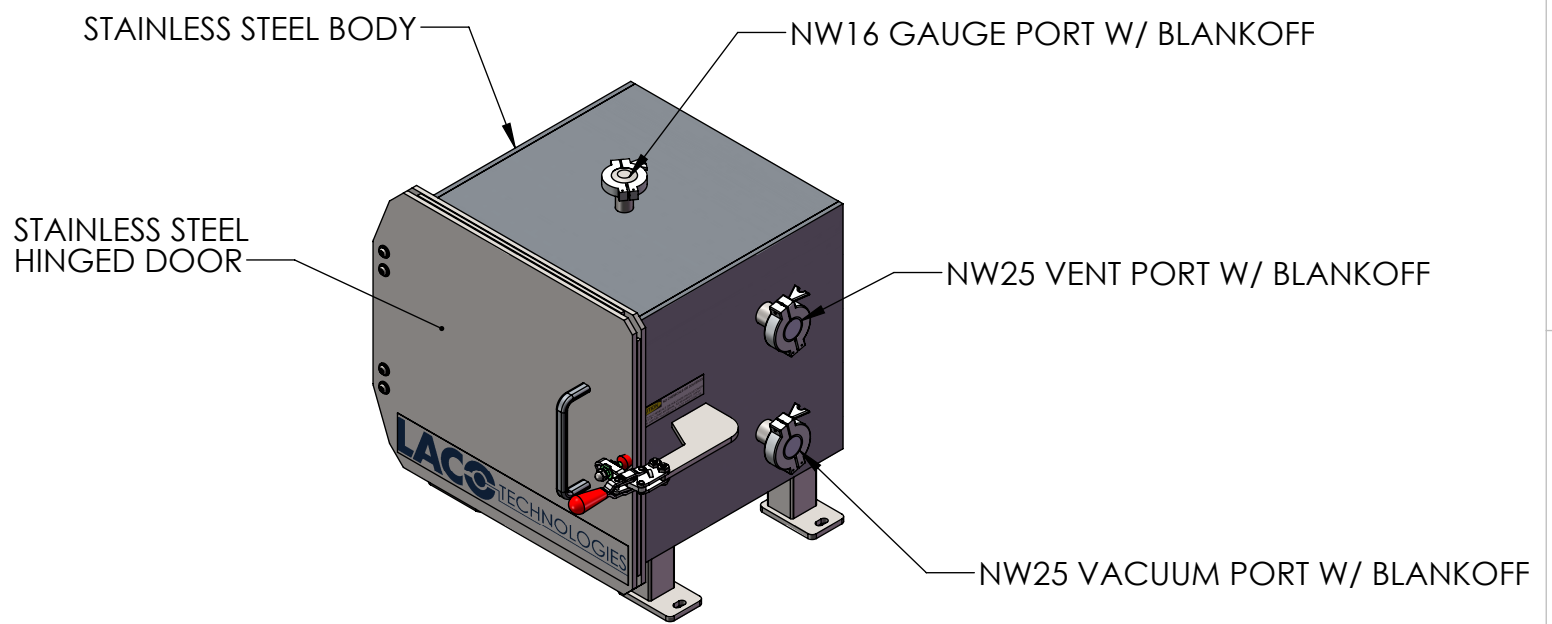

UNLESS OTHERWISE SPECIFIED:
DIMENSIONS ARE IN INCHES.
TOLERANCES:
FRACTIONAL: ±1/16"
ANGULAR: MACH ±1° / BEND ±2°
ONE PLACE DECIMAL: ±.05
TWO PLACE DECIMAL: ±.01
THREE PLACE DECIMAL: ±.005
GEO TOLERANCING: ASME Y14.5M - 2009

CHAMBER, 12" X 12" CUBE, SS BODY, SS DOOR, HORIZONTAL, STD PORTS

DRAWN BY	NAME	DATE
SEE ABAS FOR APPROVER	JRA	16 APR 2018

DWG. NO. **113058-C** REV **A**

SCALE: 1:8 SIZE: B SHEET 1 OF 1

PROPRIETARY AND CONFIDENTIAL
THE INFORMATION CONTAINED IN THIS DRAWING IS THE SOLE PROPERTY OF LACO TECHNOLOGIES, INC. ANY REPRODUCTION IN PART OR AS A WHOLE WITHOUT THE WRITTEN PERMISSION OF LACO TECHNOLOGIES, INC., IS PROHIBITED.