

REV.	LCO No.	REV DESCRIPTION	DATE	APPROVED
A	1255	INITIAL RELEASE	4/17/2018	JRA

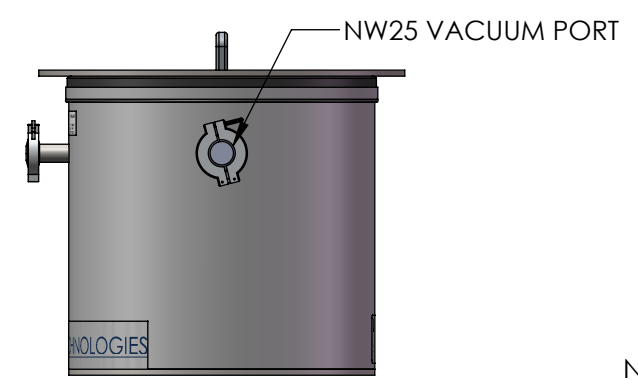

NOTES:
1. ESTIMATED SYSTEM WEIGHT: 49 lbs

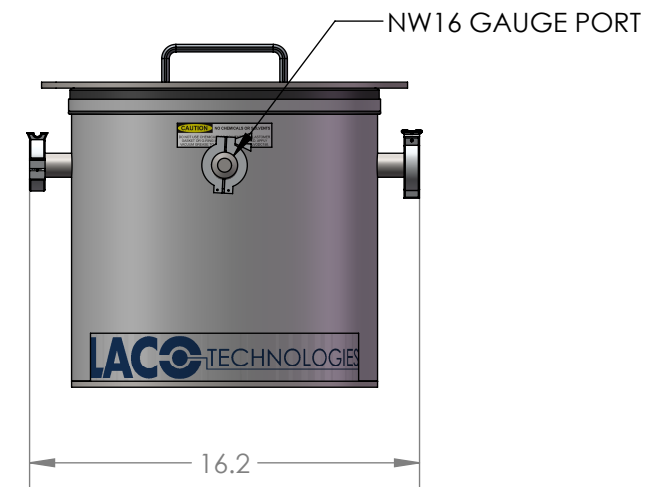
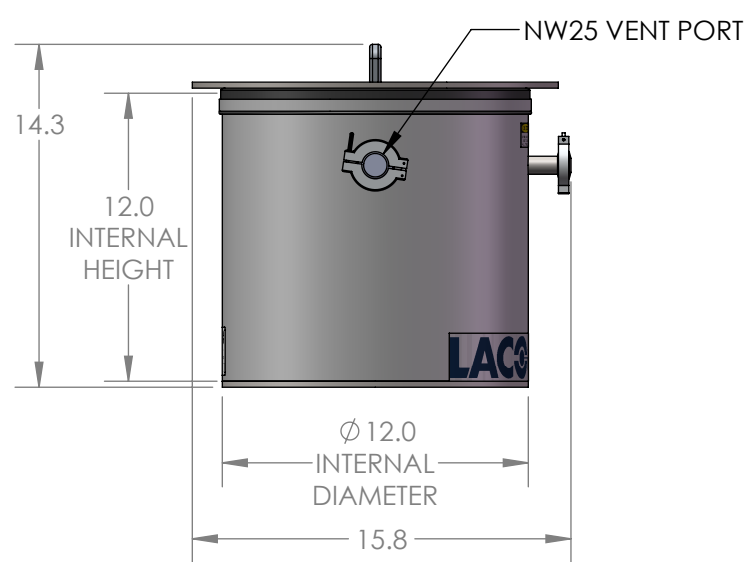
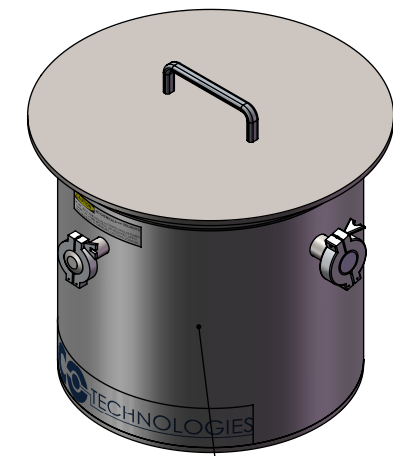
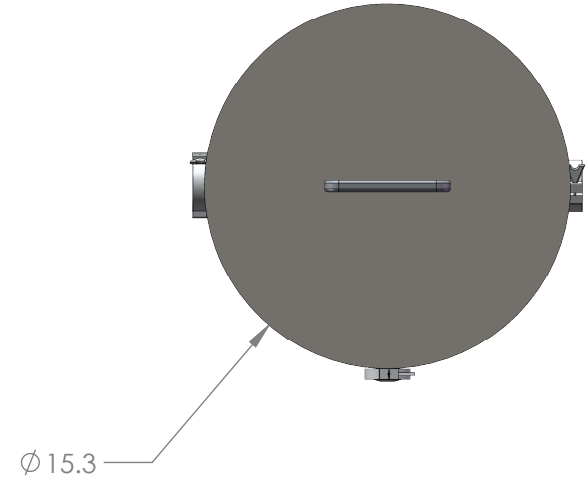

UNLESS OTHERWISE SPECIFIED:
DIMENSIONS ARE IN INCHES.
TOLERANCES:
FRACTIONAL: ±1/16"
ANGULAR: MACH ±1° / BEND ±2°
TWO PLACE DECIMAL: ±.03
THREE PLACE DECIMAL: ±.005
GEOMETRIC TOLERANCING PER ASME Y14.5M - 2009

PROPRIETARY AND CONFIDENTIAL
THE INFORMATION CONTAINED IN THIS DRAWING IS THE SOLE PROPERTY OF LACO TECHNOLOGIES, INC. ANY REPRODUCTION IN PART OR AS A WHOLE WITHOUT THE WRITTEN PERMISSION OF LACO TECHNOLOGIES, INC., IS PROHIBITED.

12" X 12" VERTICAL, SS, REMOVABLE SS LID, STANDARD PORTS, HIGH VAC		
DRAWN BY	NAME	DATE
SEE ABAS FOR APPROVER	JRA	2/7/2018
DWG. NO.	REV	
112676-C	A	
SCALE: 1:8	SIZE: B	SHEET 1 OF 1