

REV.	LCO No.	REV DESCRIPTION	DATE	APPROVED
A	1255	INITIAL RELEASE	4/17/2018	JRA

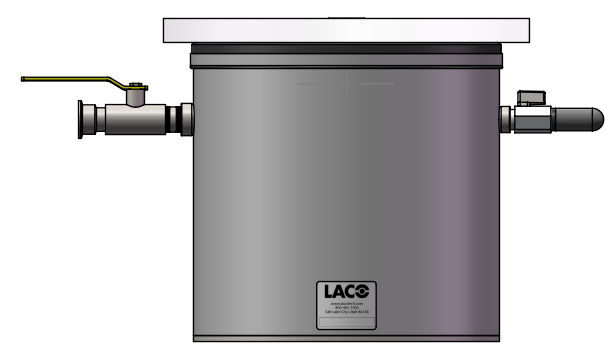
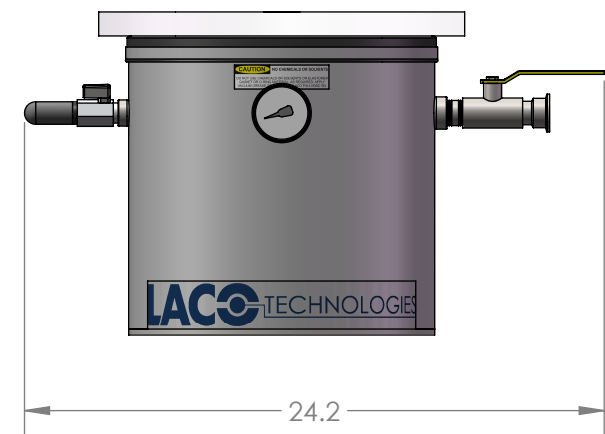
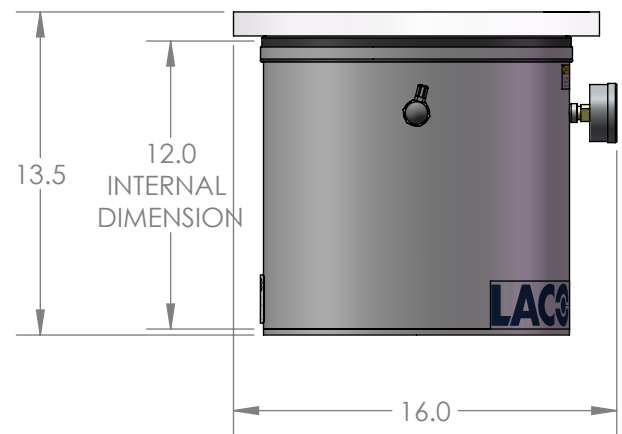
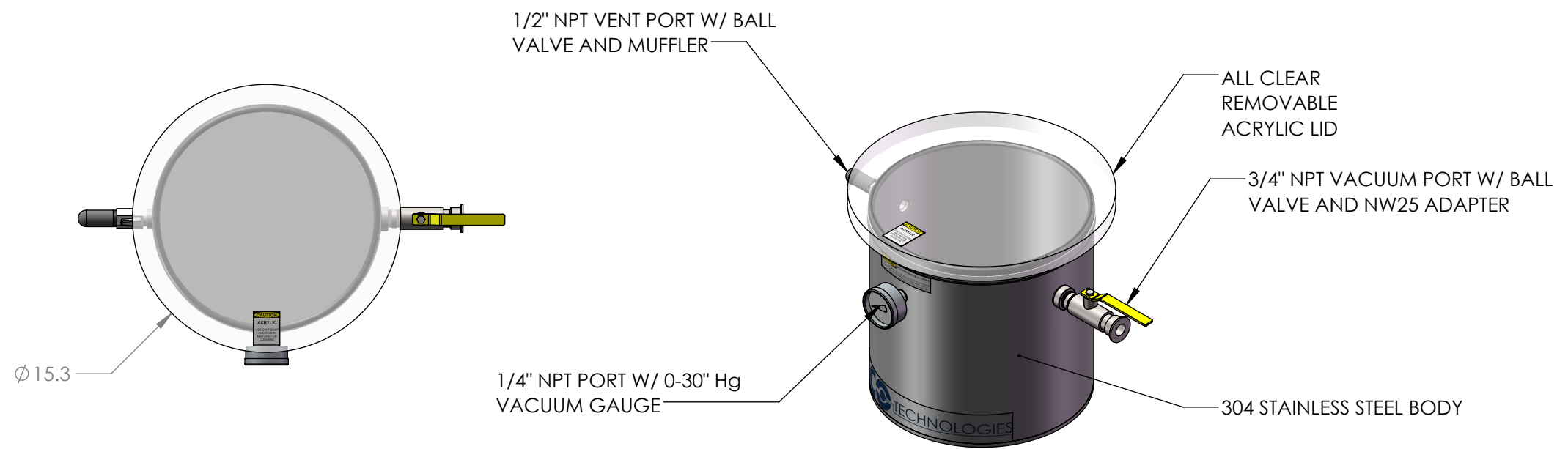

NOTES:
1. ESTIMATED SYSTEM WEIGHT: 45 lbs

LACO TECHNOLOGIES

UNLESS OTHERWISE SPECIFIED:
DIMENSIONS ARE IN INCHES.
TOLERANCES:
FRACTIONAL: ±1/16"
ANGULAR: MACH ±1° / BEND ±2°
TWO PLACE DECIMAL: ±.03
THREE PLACE DECIMAL: ±.005
GEOMETRIC TOLERANCING PER ASME Y14.5M - 2009

PROPRIETARY AND CONFIDENTIAL
THE INFORMATION CONTAINED IN THIS DRAWING IS THE SOLE PROPERTY OF LACO TECHNOLOGIES, INC. ANY REPRODUCTION IN PART OR AS A WHOLE WITHOUT THE WRITTEN PERMISSION OF LACO TECHNOLOGIES, INC., IS PROHIBITED.

12" X 12" VERTICAL, SS, REMOVABLE ACR LID, STD CHAMBER

DRAWN BY	NAME	DATE
SEE ABAS FOR APPROVER	JRA	2/8/2018

DWG. NO. **112681-C** REV **A**

SCALE: 1:8 SIZE: B SHEET 1 OF 1