

REV.	LCO No.	REV DESCRIPTION	DATE	APPROVED
A	1254	INITIAL RELEASE	6/11/2018	ABS

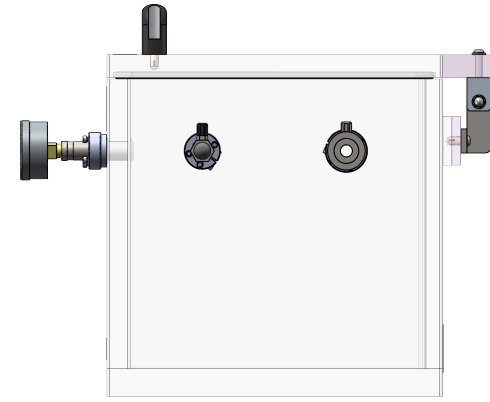

NOTES:
1. ESTIMATED SYSTEM WEIGHT: 51.5 lbs

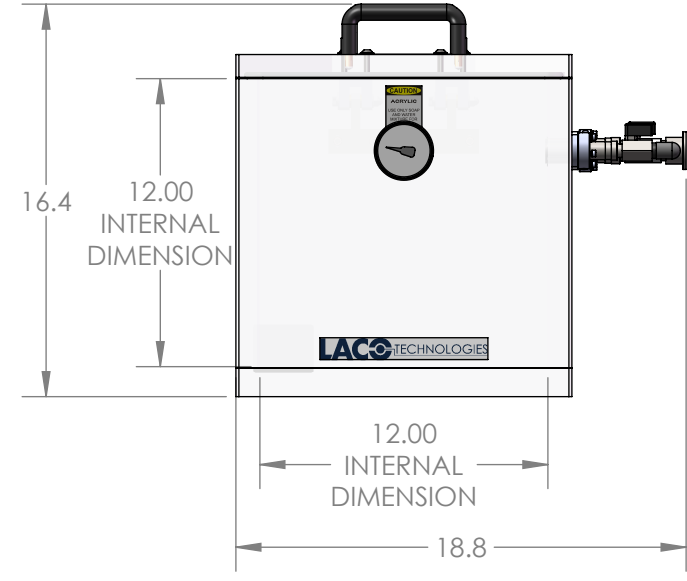
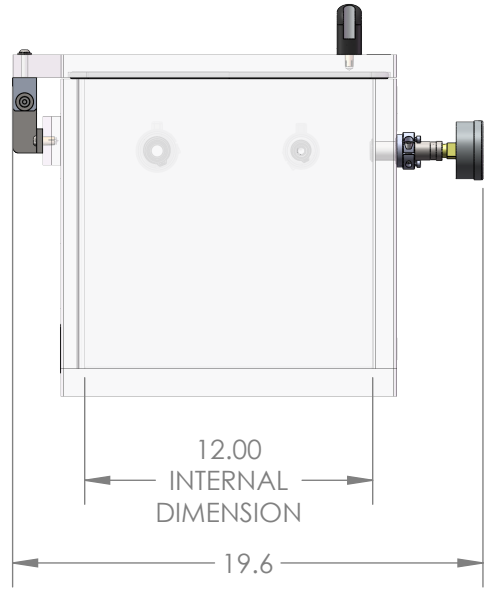
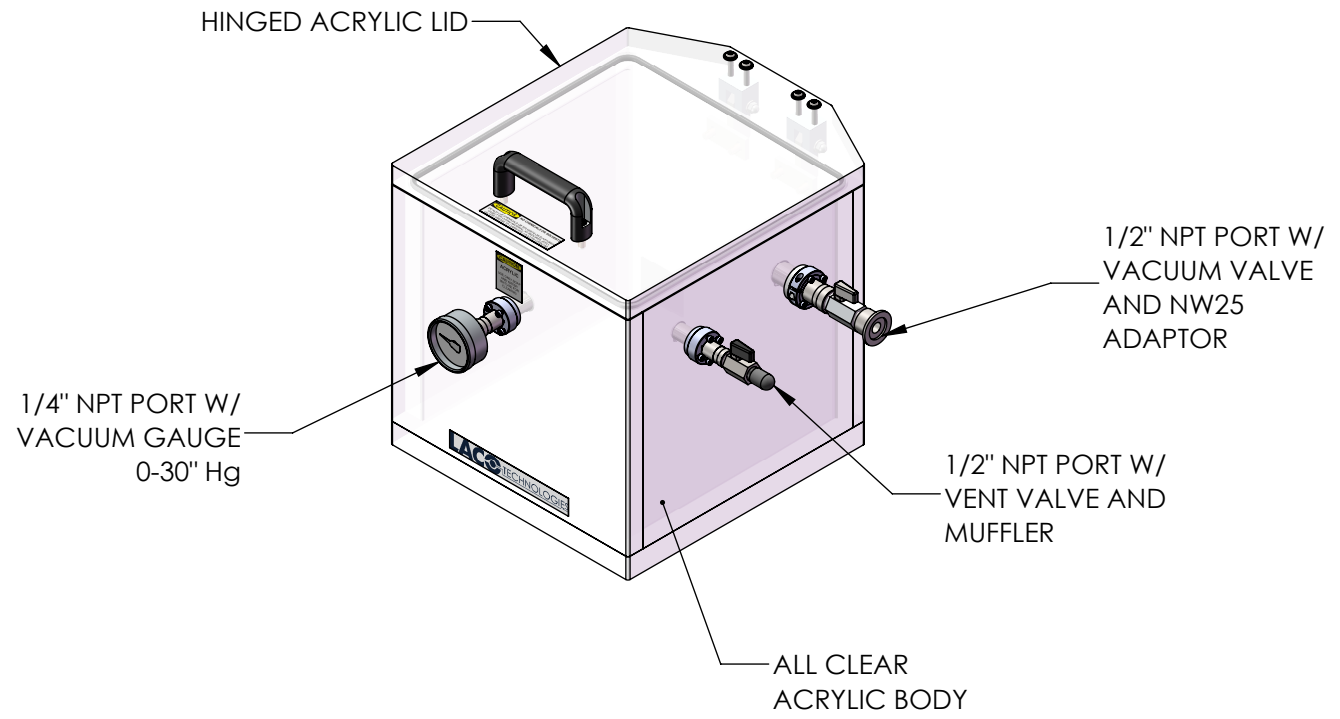
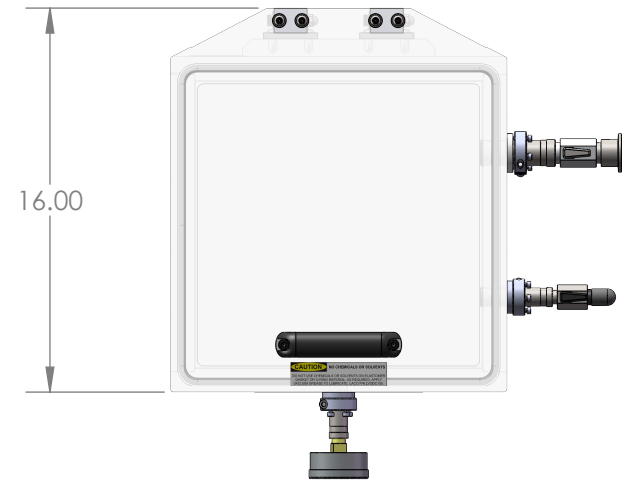

<p>UNLESS OTHERWISE SPECIFIED: DIMENSIONS ARE IN INCHES. TOLERANCES: FRACTIONAL: ±1/16" ANGULAR: MACH ±1° / BEND ±2° TWO PLACE DECIMAL: ±.03 THREE PLACE DECIMAL: ±.005 GEOMETRIC TOLERANCING PER ASME Y14.5M - 2009</p> <p>PROPRIETARY AND CONFIDENTIAL THE INFORMATION CONTAINED IN THIS DRAWING IS THE SOLE PROPERTY OF LACO TECHNOLOGIES, INC. ANY REPRODUCTION IN PART OR AS A WHOLE WITHOUT THE WRITTEN PERMISSION OF LACO TECHNOLOGIES, INC., IS PROHIBITED.</p>	<p>CHAMBER, CUBE, 12" ACRYLIC, HINGED, VERTICAL, STD PORTS</p>		
	<p>DRAWN BY</p>	<p>NAME</p> <p>ABS</p>	<p>DATE</p> <p>6/11/2018</p>
	<p>SEE ABAS FOR APPROVER</p>		
	<p>DWG. NO.</p> <p>112603-C</p>		<p>REV</p> <p>A</p>
<p>SCALE: 1:8</p>			<p>SHEET 1 OF 1</p>

8 7 6 5 4 3 2 1

8 7 6 5 4 3 2 1

D
C
B
A

D
C
B
A