

REV.	LCO No.	DESCRIPTION	DATE	APPROVED
A	1509	INITIAL RELEASE	01 May 2019	JRA

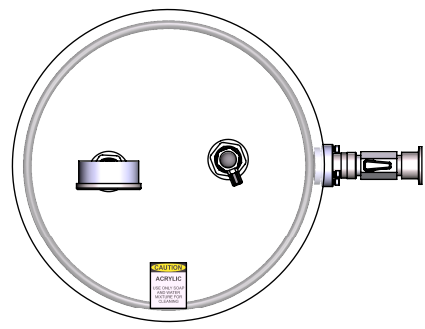

ALL CLEAR
REMOVABLE
ACRYLIC LID



ALL CLEAR
ACRYLIC BODY

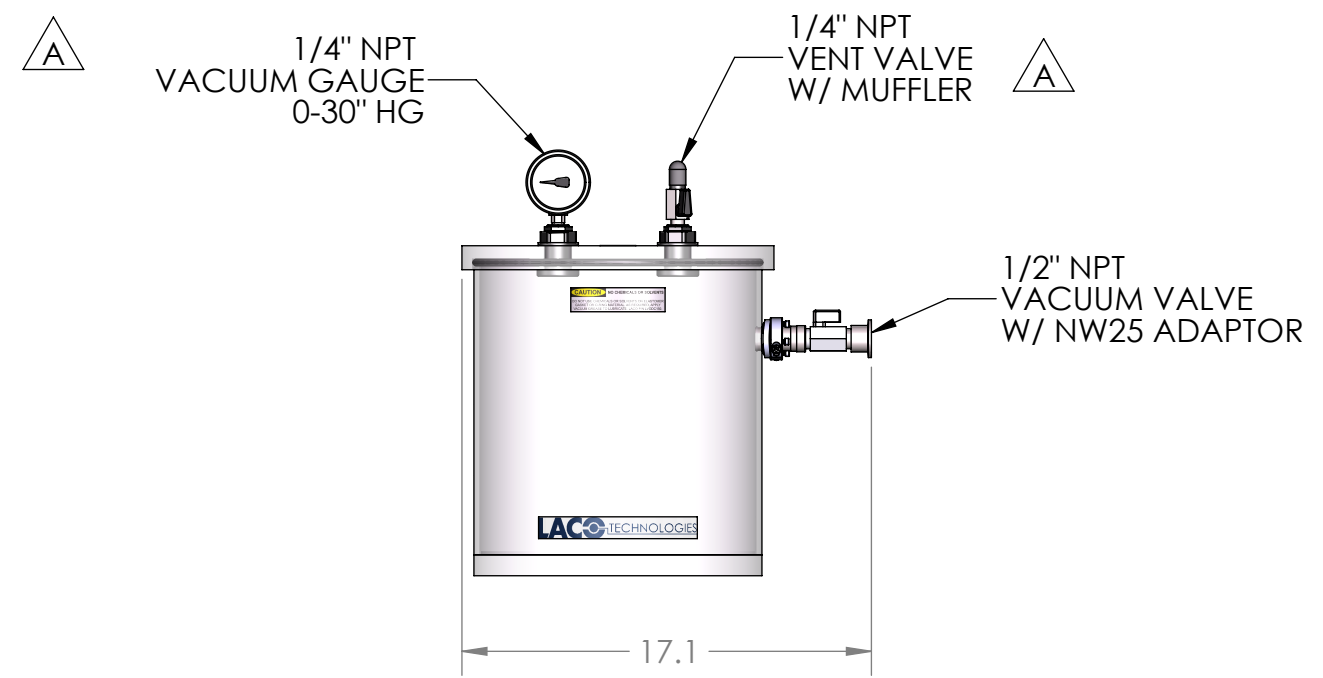
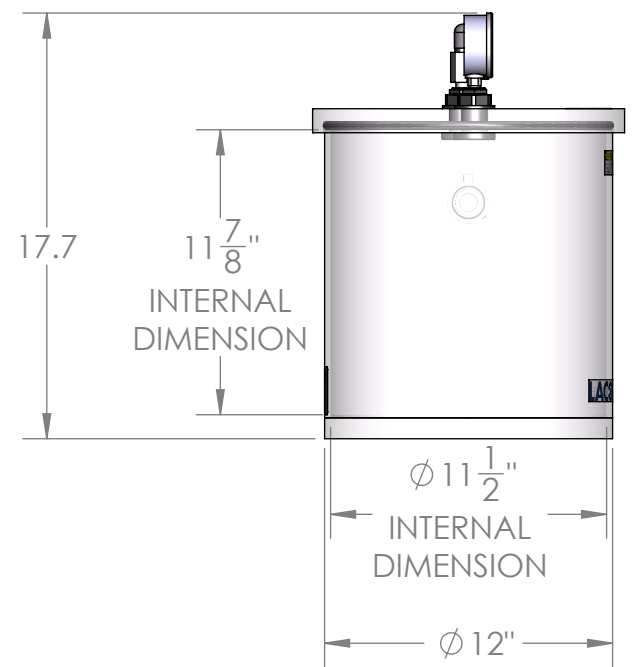

NOTES:
1. ESTIMATED SYSTEM WEIGHT: 18 lbs



UNLESS OTHERWISE SPECIFIED:
DIMENSIONS ARE IN INCHES.
TOLERANCES:
FRACTIONAL: ±1/16"
ANGULAR: MACH ±1° / BEND ±2°
ONE PLACE DECIMAL: ±.05
TWO PLACE DECIMAL: ±.01
THREE PLACE DECIMAL: ±.005
GEO TOLERANCING: ASME Y14.5M - 2009

PROPRIETARY AND CONFIDENTIAL
THE INFORMATION CONTAINED IN THIS
DRAWING IS THE SOLE PROPERTY OF LACO
TECHNOLOGIES, INC. ANY
REPRODUCTION IN PART OR AS A WHOLE
WITHOUT THE WRITTEN PERMISSION OF
LACO TECHNOLOGIES, INC., IS PROHIBITED.

CHAMBER, VERTICAL 12" X 12", ACRYLIC LVC1212-1121-VC		
DRAWN BY	NAME	DATE
SEE ABAS FOR APPROVER	ABS	7/9/2018
DWG. NO.	REV	
116384-C	A	
SCALE: 1:8	SIZE: B	SHEET 1 OF 1