

REV.	LCO No.	REV DESCRIPTION	DATE	APPROVED
A	1257	INITIAL RELEASE	4/24/2018	ABS

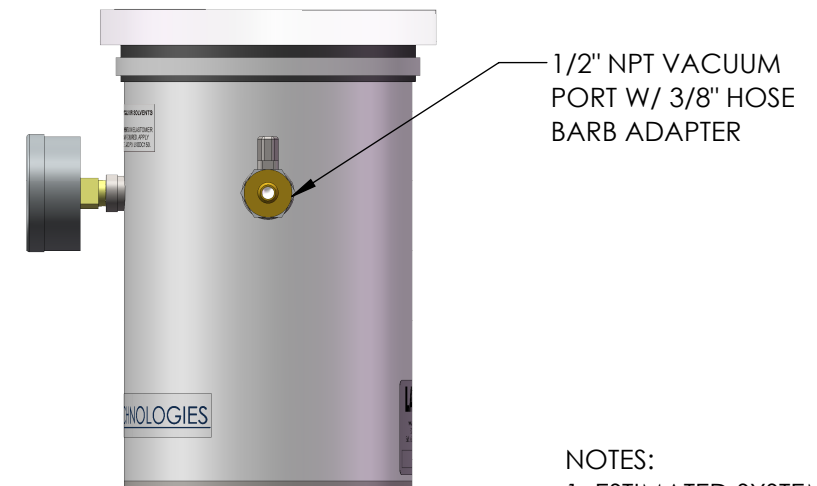

1/4" NPT PORT W/ 0-30" HG VACUUM GAUGE

NOTES:  
1. ESTIMATED SYSTEM WEIGHT: 5.1 lbs

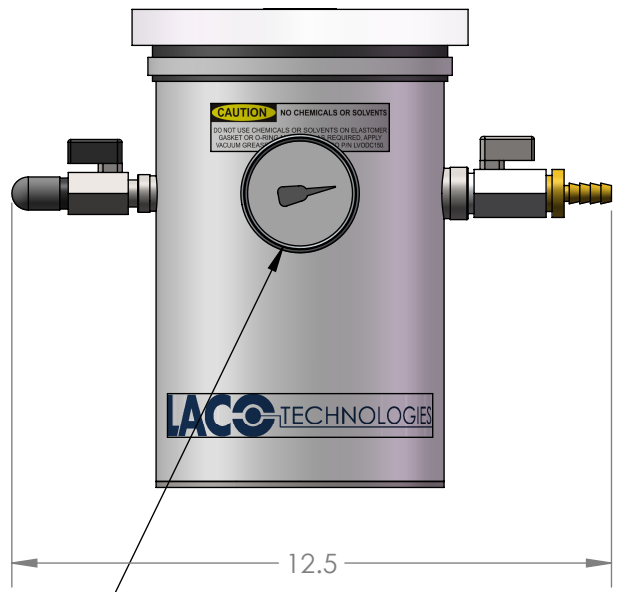
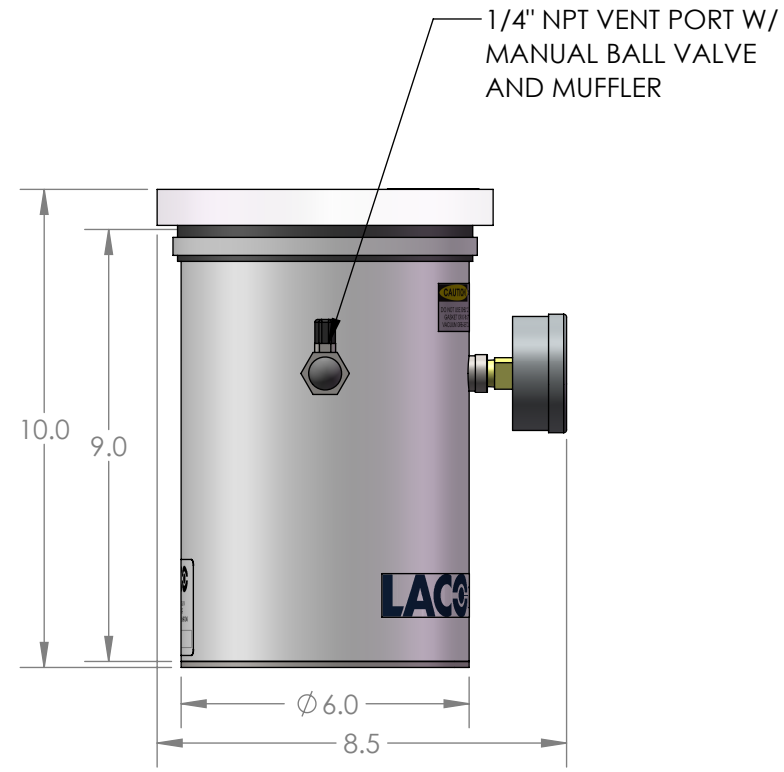
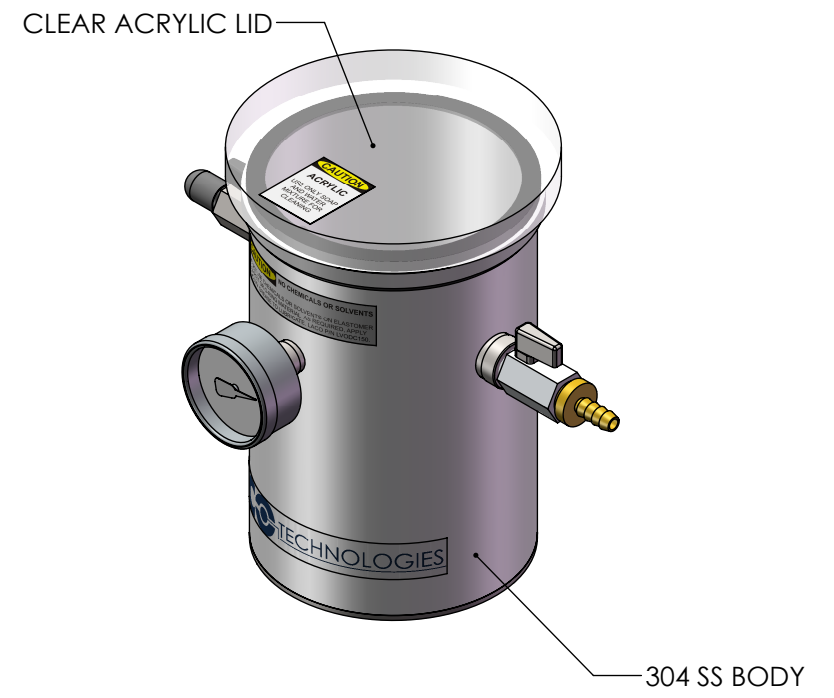
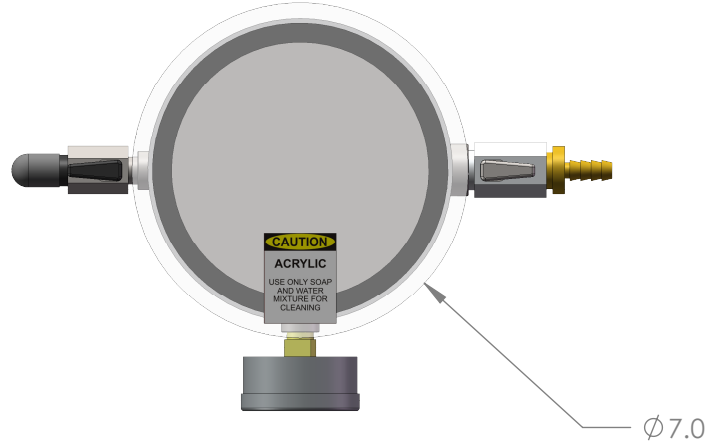

UNLESS OTHERWISE SPECIFIED: DIMENSIONS ARE IN INCHES. TOLERANCES: FRACTIONAL: ±1/16" ANGULAR: MACH ±1° / BEND ±2° TWO PLACE DECIMAL: ±.03 THREE PLACE DECIMAL: ±.005 GEOMETRIC TOLERANCING PER ASME Y14.5M - 2009			<b>CHAMBER, 6" X 9", VERTICAL, SS BODY, ACRYLIC LID, STANDARD PORTS</b>		
PROPRIETARY AND CONFIDENTIAL THE INFORMATION CONTAINED IN THIS DRAWING IS THE SOLE PROPERTY OF LACO TECHNOLOGIES, INC. ANY REPRODUCTION IN PART OR AS A WHOLE WITHOUT THE WRITTEN PERMISSION OF LACO TECHNOLOGIES, INC., IS PROHIBITED.					
DRAWN BY		NAME	DATE		
SEE ABAS FOR APPROVER		JRA	5/11/2018		
DWG. NO.			REV		
112745-C			A		
SCALE: 1:4		SIZE: B	SHEET 1 OF 1		