

CUSTOMER APPROVAL DRAWING
(Not for Manufacturing Use)

REV.	LCO No.	DESCRIPTION	DATE	APPROVED
A	1475	INITIAL RELEASE	1/29/2019	ABS
B		REMOVED TICKET PRINTER COVER	4/13/2023	MST

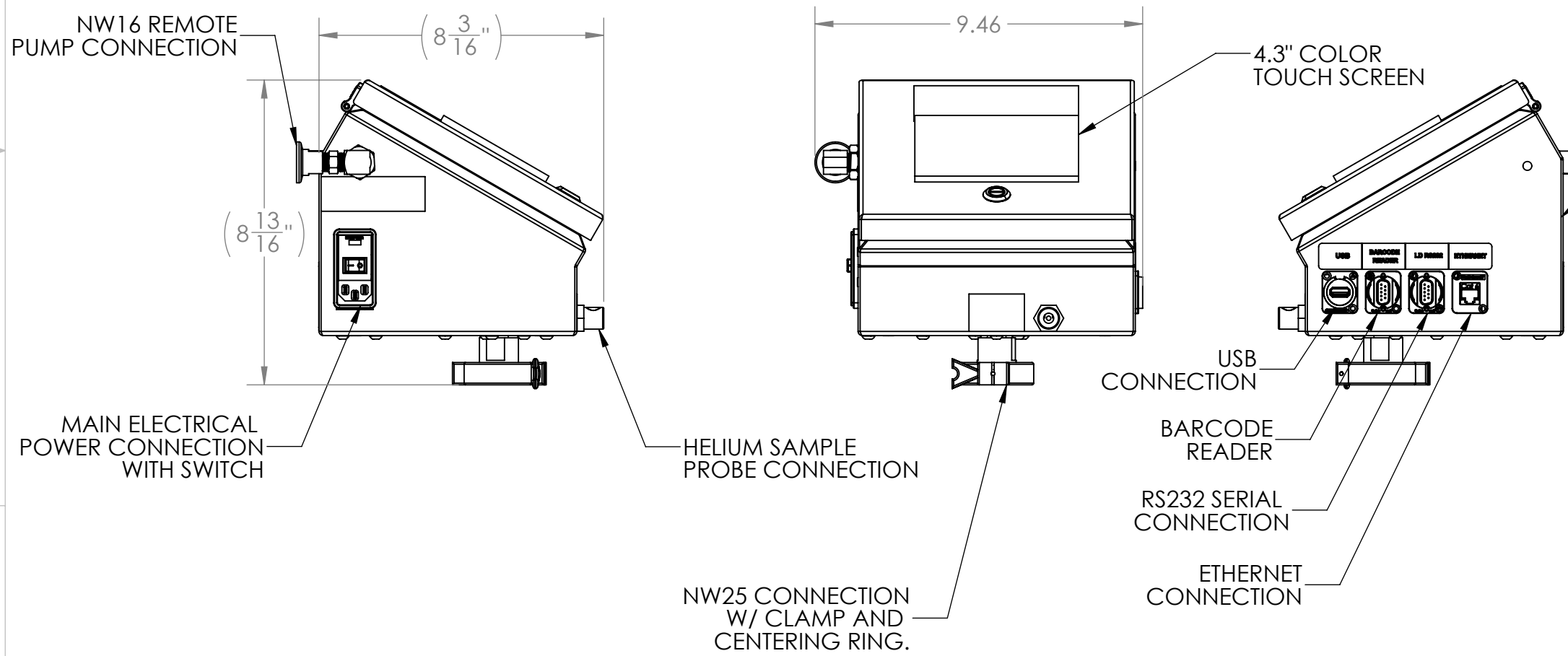

NOTES:

- APPROX WEIGHT: 5.5 LBS.
- ELECTRICAL REQUIREMENT: 90-260 VAC. 5 AMPS MAX.



UNLESS OTHERWISE SPECIFIED: DIMENSIONS ARE IN INCHES. TOLERANCES: FRACTIONAL: $\pm 1/16$ " ANGULAR: MACH $\pm 1^\circ$ / BEND $\pm 2^\circ$ TWO PLACE DECIMAL: $\pm .01$ THREE PLACE DECIMAL: $\pm .005$ GEOMETRIC TOLERANCING PER ASME Y14.5M - 2009			HELIUM CONCENTRATION TESTER, REMOTE PUMP, TOP ASSEMBLY LHCT03D-R		
DRAWN BY		NAME	DATE		
APPROVED BY		MEC	08/15/13		
DWG. NO.			REV		
96355-R-M			B		
SCALE: 1:4		SIZE: B	SHEET 1 OF 1		

PROPRIETARY AND CONFIDENTIAL
THE INFORMATION CONTAINED IN THIS DRAWING IS THE SOLE PROPERTY OF LACO TECHNOLOGIES, INC. ANY REPRODUCTION IN PART OR AS A WHOLE WITHOUT THE WRITTEN PERMISSION OF LACO TECHNOLOGIES, INC., IS PROHIBITED.