

ID	FEATURE
1	BOMBING CHAMBER
2	EVAC PUMP (WET OR DRY)
3	HELIUM GAS CHARGE MANIFOLD

REV.	LCO No.	REV DESCRIPTION	DATE	APPROVED
A	---	INITIAL RELEASE	02/14/2023	MST

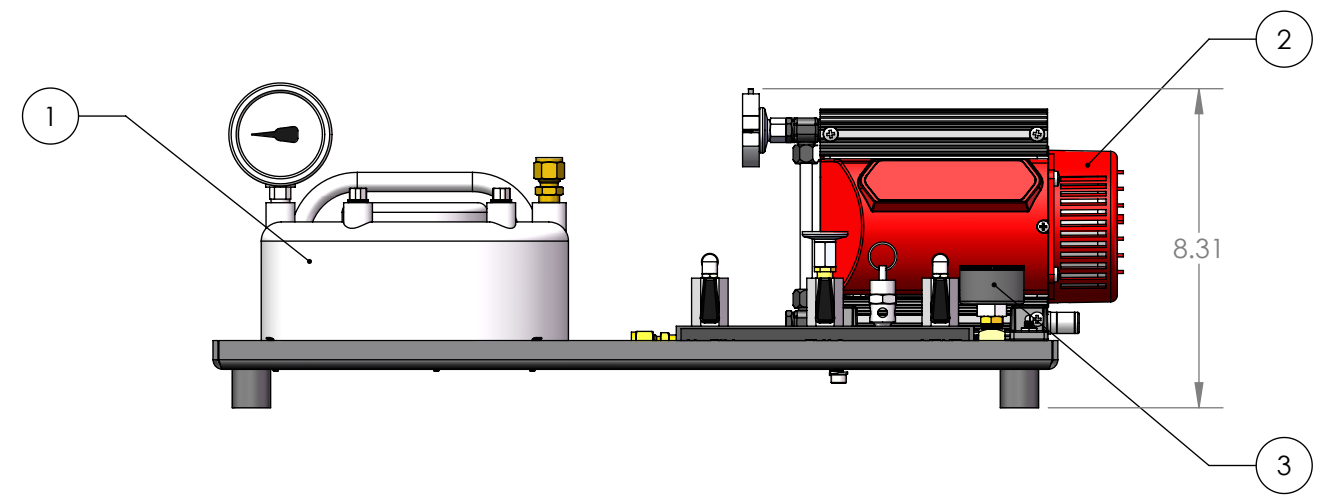

- NOTES:
 1. SYSTEM WEIGHT - KG(LB)
 14 (31)
 2. SEE OPERATIONS MANUAL FOR MORE DETAIL

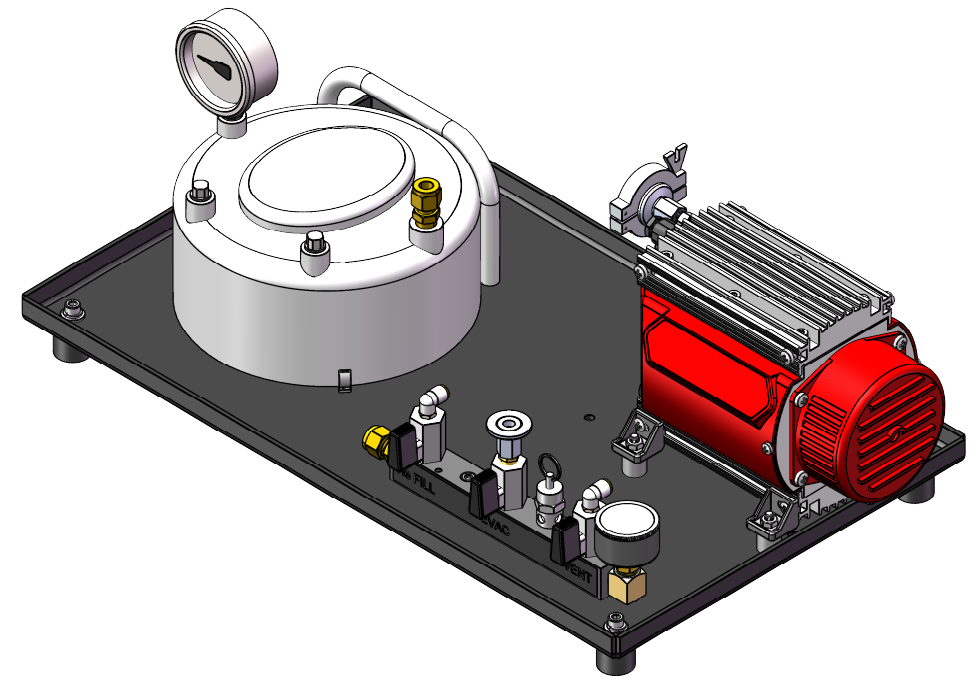
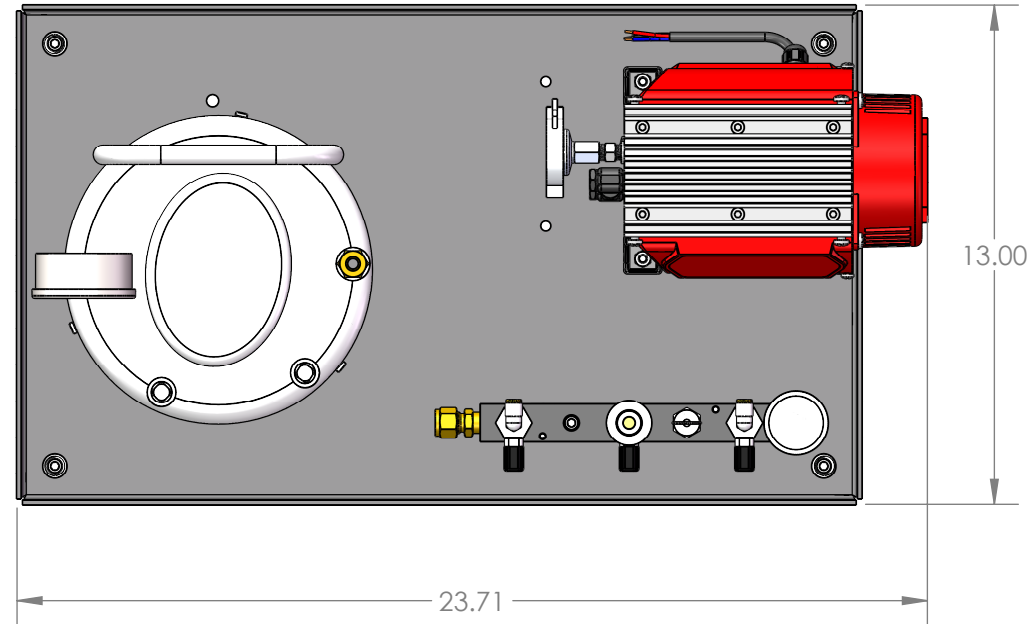

UNLESS OTHERWISE SPECIFIED: DIMENSIONS ARE IN INCHES. TOLERANCES: FRACTIONAL: ±1/16" ANGULAR: MACH ±1° / BEND ±2° TWO PLACE DECIMAL: ±.03 THREE PLACE DECIMAL: ±.005 GEOMETRIC TOLERANCING PER ASME Y14.5M - 2009			HELIUM BOMBING SYSTEM 8X3, LMGC. EVAC PUMP, BASEPLATE CUSTOMER DRAWING		
DRAWN BY		NAME	DATE		
SEE ABAS FOR APPROVER		MST	2/14/2023		
DWG. NO. 126879-2C				REV	A
SCALE: 1:5		SIZE: B	SHEET 1 OF 1		

8 7 6 5 4 3 2 1

D
C
B
A

D
C
B
A

8 7 6 5 4 3 2 1