

ID	FEATURE
1	BOMBING CHAMBER
2	HELIUM GAS CHARGE MANIFOLD

REV.	LCO No.	REV DESCRIPTION	DATE	APPROVED
A	---	INITIAL RELEASE	02/16/2023	MST

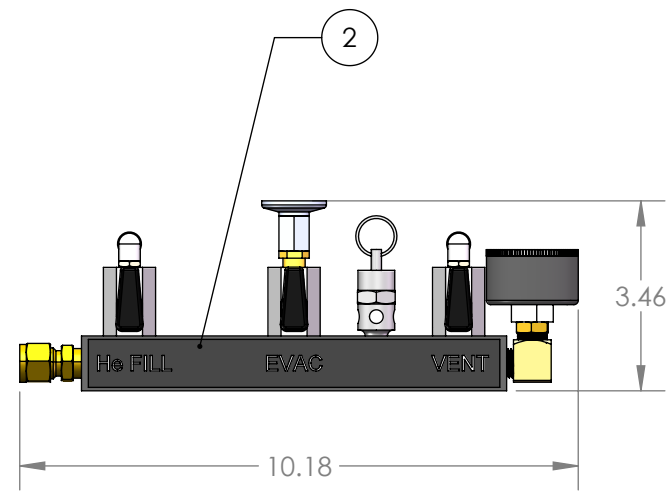

- NOTES:
- SYSTEM WEIGHT - KG(LB)- TOTAL WEIGHT 8.2 (18)
 CHAMBER: 6.8 (15)
 MANIFOLD: 1.4 (3)
 - SEE OPERATIONS MANUAL FOR MORE DETAIL.

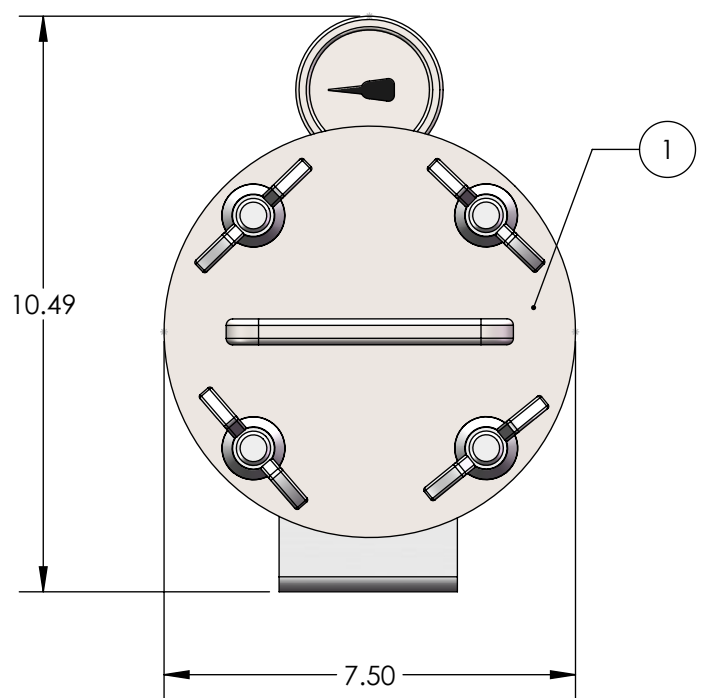
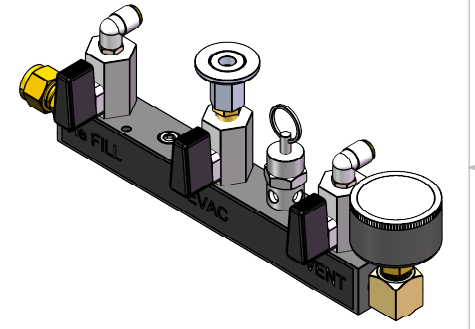
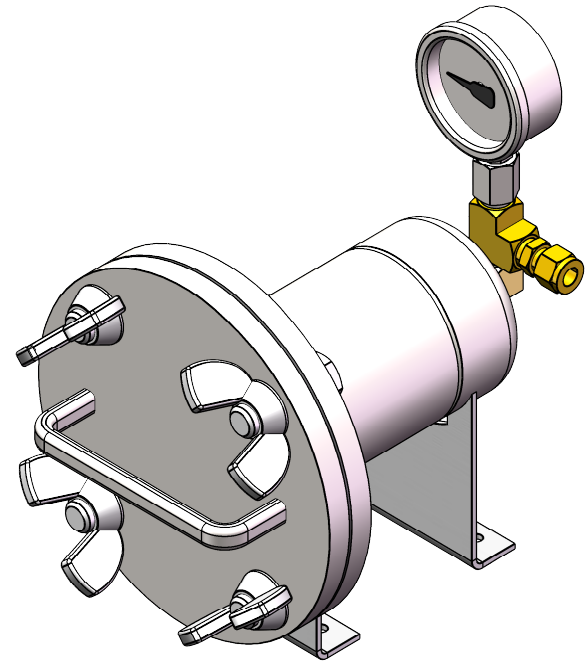
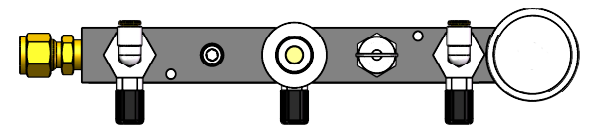
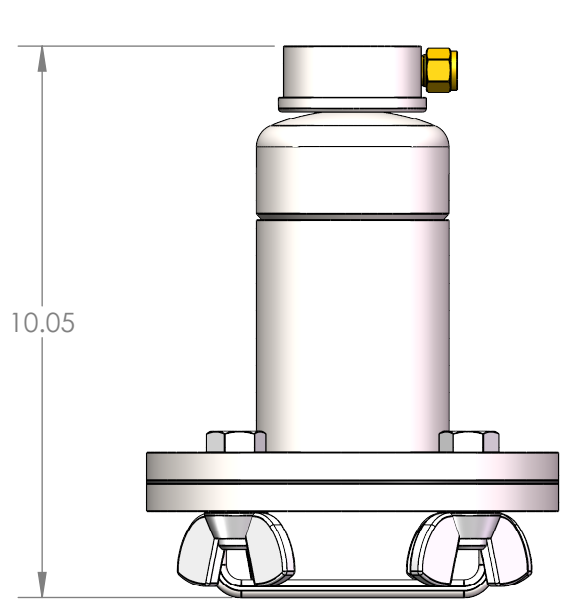

UNLESS OTHERWISE SPECIFIED: DIMENSIONS ARE IN INCHES. TOLERANCES: FRACTIONAL: ±1/16" ANGULAR: MACH ±1° / BEND ±2° TWO PLACE DECIMAL: ±.03 THREE PLACE DECIMAL: ±.005 GEOMETRIC TOLERANCING PER ASME Y14.5M - 2009		
HELIUM BOMBING SYSTEM 3X6, LMGC, NO PUMP, OPEN STYLE, CUSTOMER DRAWING		
DRAWN BY	NAME	DATE
SEE ABAS FOR APPROVER	MST	2/16/2023
DWG. NO.	REV	
126878-1C	A	
SCALE: 1:3.5	SIZE: B	SHEET 1 OF 1

PROPRIETARY AND CONFIDENTIAL
 THE INFORMATION CONTAINED IN THIS
 DRAWING IS THE SOLE PROPERTY OF LACO
 TECHNOLOGIES, INC. ANY
 REPRODUCTION IN PART OR AS A WHOLE
 WITHOUT THE WRITTEN PERMISSION OF
 LACO TECHNOLOGIES, INC., IS PROHIBITED.